

ENGINE ELECTRONIC SYSTEM

INPUT / OUTPUT COMPONENTS OF CONTROL SYSTEM	E-2
WORKING MODULE TABLE OF FUEL INJECTION / IGNITION SYSTEM ...	E-3
WORKING PRINCIPLE	E-4
ELECTRICAL CONTROL UNIT	E-5
WORKING PRINCIPLE OF ELECTRONIC FUEL INJECTION CONTROL AND ACTUATORS	E-7
BASIC PRINCIPLE OF MALFUNCTION DIAGNOSIS FOR ELECTRONIC FUEL INJECTION SYSTEM	E-21
DETAILED TABLE OF MALFUNCTION DIAGNOSTIC CODE	E-24
PROCEDURES FOR FAULT DIAGNOSIS ACCORDING TO THE SYMPTOMS OF THE ENGINE	E-62
SAFETY PRECAUTIONS OF SYSTEM MAINTENANCE	E-88
SAFETY PRECAUTIONS IN DIAGNOSIS AND MAINTENANCE OF THE GASOLINE INJECTION ELECTRONIC CONTROL SYSTEM	E-88
SAFETY MEASURES	E-89

INPUT / OUTPUT COMPONENTS OF CONTROL SYSTEM

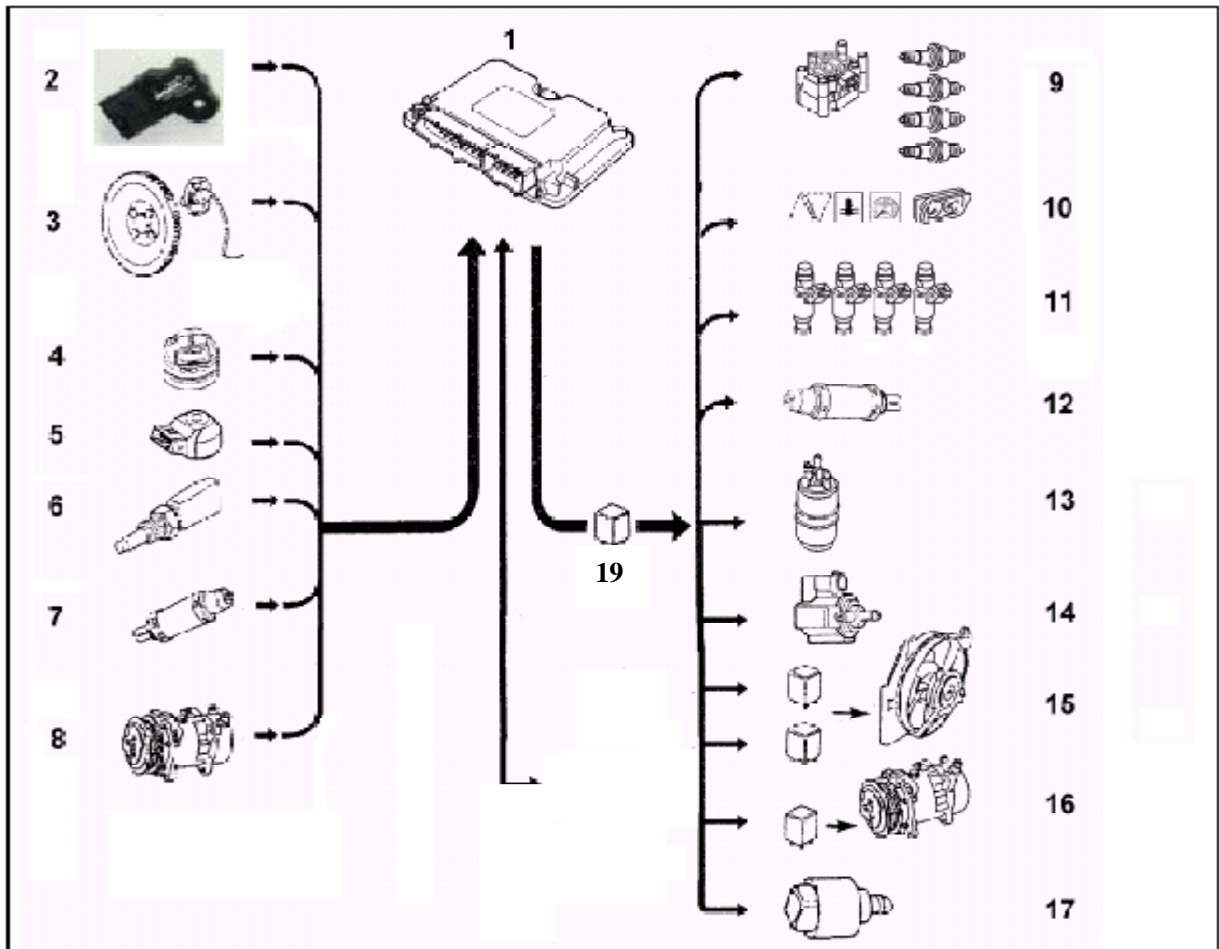

- | | | | |
|----|---|----|--------------------------------|
| 1 | Engine ECU | 11 | Fuel injector |
| 2 | Air pressure / temperature sensor | 12 | Oxygen sensor (heater) |
| 3 | Engine speed sensor for top dead center | 13 | Fuel pump |
| 4 | Throttle valve position sensor | 14 | Carbon canister solenoid valve |
| 5 | Knock sensor | 15 | Two step speed fan controller |
| 6 | Coolant temperature sensor | 16 | Compressor relay control |
| 7 | Oxygen sensor (λ signal) | 17 | Idling speed step motor |
| 8 | Air condition request | 18 | Diagnostic connection |
| 9 | Ignition coil and spark plugs | 19 | Relay |
| 10 | Instrument panel | | |

WORKING MODULE TABLE FOR FUEL INJECTION / IGNITION SYSTEM

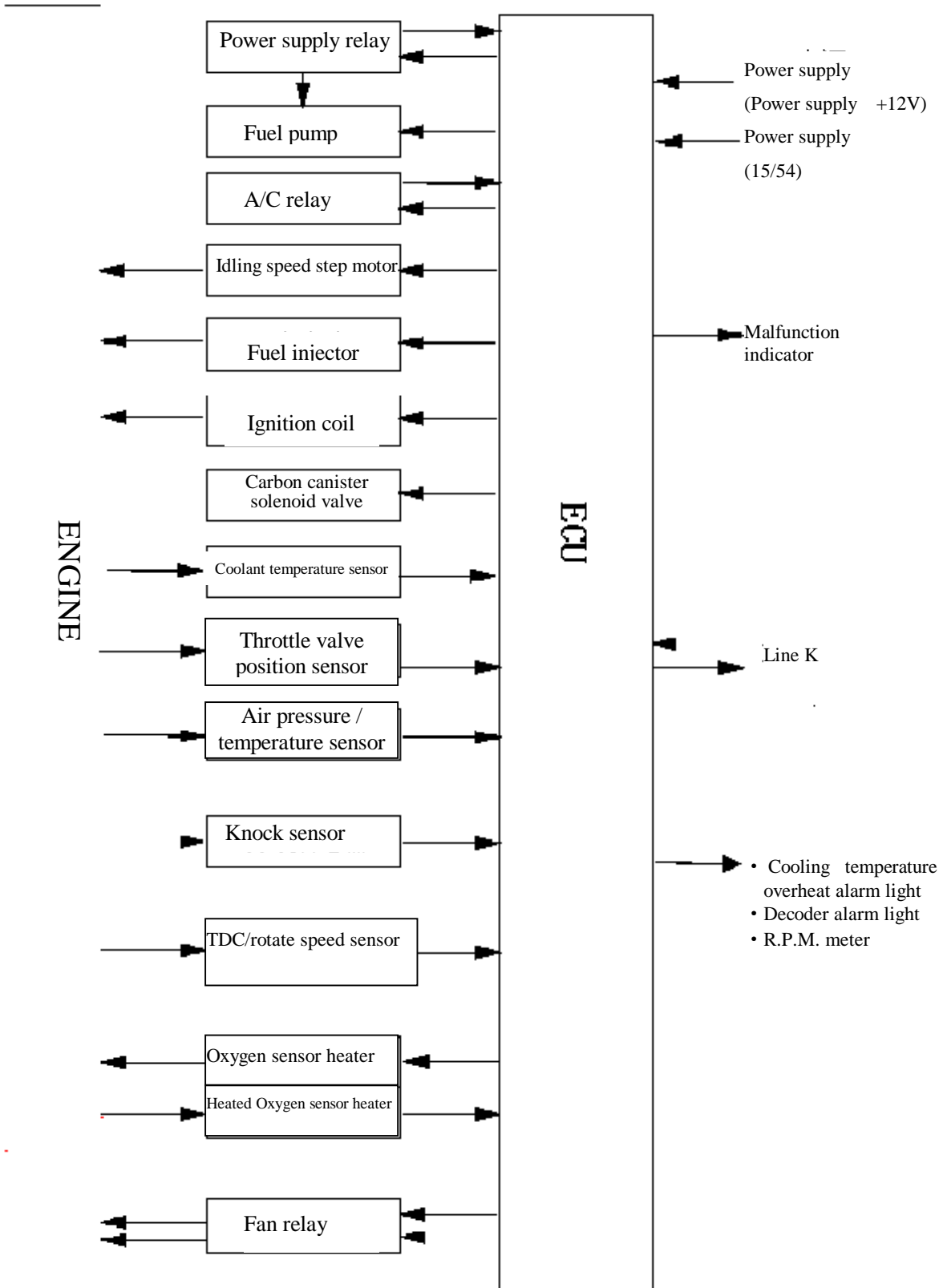

WORKING PRINCIPLE

This system is capable of controlling the actual tested air-fuel ratio under all engine speeds to stay close to the equivalent proportion of the chemical reaction, so as to protect the catalyst package and subsequently reduce the discharge of pollution. The oxygen sensor analyses the oxygen content of the discharge gas using real-time principle and makes it possible for the ECU to control the amount of injecting fuel to correct the air-fuel ratio. The fuel with a pressure of about 3.5 bars is directly injected into the air intake manifold near the throttle valve.

The fuel injectors of all cylinders are utilizing a sequential phase angle control method according to the intake sequence and the opening time of the air intake valves; the injection destinations are stored in the ECU map, and can vary autonomously according to the engine speeds and intake air pressures. The application of sensors in the system is a basic strategy used to correct the engine under all operating conditions. The system is implementing an induction type of electrical discharge ignition, where the power source module in the ECU controls the ignition timing. The ignition advance angle is calculated according to the engine compression ratio and intake air volume. The idling speed is maintained at stable condition through controlling the opening of the branch-connection pipe by a step motor and also through the changing of the ignition points.

Other than capable of obtaining the input signals and controlling the output components, the system has also equipped with various other functions. These functions include the following:

- When self-diagnose that the sensor is faulty, adopt the restoration strategic control.
- Restoration of the self-regulating mixed concentration engine and variances in spare parts.
- Exchange data with the diagnostic tester.

The idling speed of the engine and the amount of CO in the air discharged must not be manually adjusted.

ELECTRONIC CONTROL UNIT

The ECU is located on the left of engine firewall. The ECU handles various signals from the sensors and controls the actuator so as to achieve the best possible operating condition. Many extra functions are added as compared with the previous model. While by the usage of a custom-made circuit board that can achieve many special functions, the integrated functions are enhanced so that the structure has considerably reduced in size and become much more compact.

The hard wares in the ECU are as follows:

- 16 bit CPU single chip
- 8KB RAM (2KB IRAM + 6KB ERAM)
- 2MB FLASH EPROM (12V programming voltage)
- 2KB SERIAL EEPROM
- 16 CHANNELS 10 MODULES/NO. (A/D) CONVERTER
- 4PWM OUTPUT
- CAN MODULE (CAN2.0B)

The ECU software structure is divided into two parts for data processing:

- The “Application” part obtained the measurement of engineering parameter through sensors to calculate the control parameters of the fuel injectors, ignition coils and idling speed step motor for controlling the engine starting.
- The “Basic” part is collecting the data from the sensors and converts it into engineering data. After that it controls the actuator through the calculated parameter generated by the “application” software, and manages the self-diagnostic programs of the various sensors and actuators. In addition, it can also communicate with the externally connected diagnostic tester through the use of “K” serial cable.

The operating system is capable of ensuring the accurate management of the matters related with time (such as the management of definite and delay timing) and angles (related to the engine rotation sequence). This type of management is integrated in the software and calculated according to the precise priority to ensure the optimization management of the engine even at its high-speed condition. This type of “modular structure” design allows the possibility of achieving all kinds of flexibility control and in the mean time not tampering the overall characteristic of the system.

The following data are transmitted into the ECU:

- Battery voltage
- Absolute pressure sensor in the air intake manifold
- Top dead center
- Throttle valve opening angle position
- Air intake temperature

- Engine coolant temperature
- Air conditioning operation
- Signal from oxygen sensor
- Knock sensor for the accelerator meter on top of the engine crankshaft housing

The air intake efficiency is obtained by calculating through the processing of absolute pressure, air intake temperature, engine speed, throttle valve position and other signals, and help to determine the air intake quantity of the cylinder. The inbuilt power supply module in the ECU is controlling the following functions:

- To control the injected fuel quantity through the control of opening timing of the fuel injector
- Idling speed step motor
- Ignition coils of the 4 high voltage outputs
- Check valve for recirculation the gaseous fuel on top of the air intake manifold (carbon canister)
- Temporary turnoff of the air condition compressor
- Dual speed cooling fan for the engine
- Overheating alarm light in the coolant of the engine
- Malfunction alarm light

Other than these major functions, ECU also controls:

- All the self-diagnostic strategy related to input sensors and output actuators
- Wrong signals restoration strategy works on basically effective input signals

WORKING PRINCIPLE OF ELECTRONIC FUEL INJECTION CONTROL AND ACTUATORS

※Intake Pressure and Intake Air Temperature Sensor

Purpose: detects manifold absolute pressure from 0.1~0.2bar and intake air temperature, provides engine with load information.

Composition and principle: this sensor is composed of two different sensors (i.e. manifold absolute pressure sensor and intake temperature sensor), and is installed above pressurizer.

Pressure-sensitive element inside **intake pressure sensor** detects pressure signal on intake manifold for injection pulse width control of EFI system. This sensor also serves as the substitute of load signal sensor.

Intake air temperature sensing element is a resistor of negative temperature coefficient (NTC), which is similar to water temperature sensor with resistance value decreasing with the increasing of intake air temperature. And engine ECU monitors the variation of intake air temperature via a comparison circuit inside.

Failure diagnosis: The electronic device next to intake pressure sensor detects sensor circuit troubles such as open circuit, short circuit and sensor damages, etc. In case ECU detects any sensor output signal that goes beyond output characteristic curve, the sensor is diagnosed as failed by ECU. For example: when intake pressure is higher than upper limit or lower than lower limit, ECU detects sensor failure (in case that intake pressure is lower than lower limit when starting, ECU is able to recognize the starting condition), and the engine fault indicating lamp goes on. Under this condition the engine works in failure mode.

Installation: to be installed on pressurizer.



TMAP

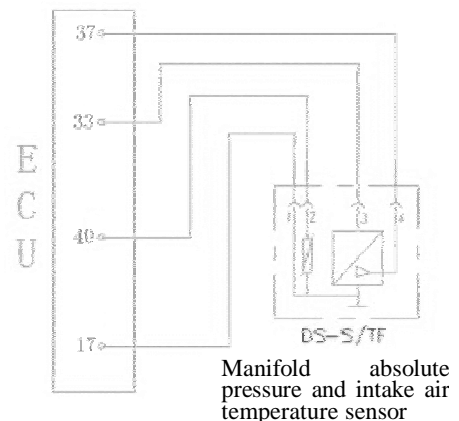

Circuit diagram of manifold absolute pressure and intake air temperature sensor

Pins:

- 1# is grounded (connecting ECU 17#);
- 2# outputs temperature signal (connecting ECU 40#);
- 3# connects with standard 5V power source (connecting ECU 33#);
- 4# outputs pressure signal (connecting ECU 37#).

Troubleshooting: mainly check if there is short circuit or open circuit on the connection between 4 lines on sensor and ECU.

If there is short circuit, open circuit or grounding between sensor wire harnesses.

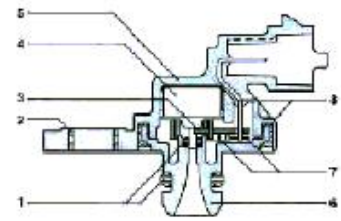

Sectional view of intake pressure and intake air temperature sensor

- | | |
|---------------------------|--------------------|
| 1 Seal ring | 5 Casing |
| 2 Stainless steel bushing | 6 Pressure bracket |
| 3 PCB | 7 Welded joint |
| 4 Sensing element | 8 Bonded joint |

※Throttle Position Sensor

Purpose: this sensor is designed to provide ECU with information of throttle angle. As per such information, ECU obtains engine load information and operating mode information (for instance: start-up, idle speed, reverse, part load and full load) as well as acceleration and deceleration information. This sensor is three-wire style, and the throttle opening can be detected by ECU via monitoring voltage variation.

Composition and principle: Consisting of two compass sliding contact resistors and two sliding contact arms, throttle position sensor is an angle sensor that outputs linear signals. The axes of contact arms are on the same axial line with throttle axis, with 5V power supply voltage US being applied to both ends of each contact resistor. When throttle turns, contact arms turn along with it and move on sliding contact resistors, educing potential of contacts UP as output voltage. This sensor is actually an angle potentiometer.

Failure diagnosis: ECU monitors throttle angle, and detects sensor failure when output signal exceeds upper or lower limit, in which case engine will work in failure mode, and fault indicating lamp will go on.

Installation: allowable tightening torque for fastening screw is 1.5Nm-2.5Nm.

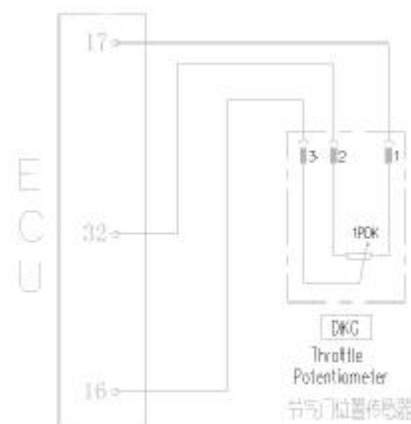

Circuit diagram of throttle position sensor

Pins:

- 1 sensor signal ground (ECU17#)
- 2 5V power (ECU32#)
- 3 sensor signal (ECU16#)

Troubleshooting: mainly check if there is short circuit or open circuit on the connection between 3 lines on sensor and ECU.

Check to see if there is short circuit, open circuit or grounding between sensor wire harnesses.

※Coolant Temperature Sensor TF-W

Purpose: this sensor is designed to provide coolant temperature information. To provide engine ECU with water temperature signal used for control of ignition timing and fuel injection pulse width in startup, idle speed and normal operation.

Composition and principle: this sensor is a thermistor of negative temperature coefficient (NTC) with resistance value decreasing with the increasing of coolant temperature except linear relation. The said thermistor is installed in a heat-conducting sleeve. ECU monitors water temperature variation by converting resistance value of thermistor into a changing voltage through a bleeder circuit (inner structure of ECU).

Failure diagnosis: When coolant temperature is higher than allowed upper limit or lower than lower limit, failure mark of the knock sensor is set, engine fault indicating lamp goes on and engine works in failure mode. In this case ECU controls ignition and fuel injection according to set water temperature for failure mode, at the same time the fan is running at high-speed mode.

Limiting data: $2.5 \pm 5\% K \Omega$

Installation hint: tightening torque is 15Nm in maximum.

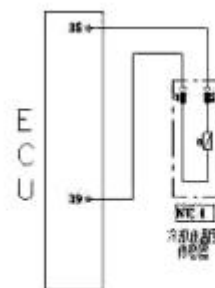

Circuit diagram of Coolant temperature sensor

Hints: the vehicle is equipped with 2 water temperature sensors, one is single-pin water temperature sensor, providing the water temperature gauge with water temperature signal; the other is double-pin, providing the engine ECU with water temperature signal.

Pins: this sensor has 3 pins, which can interchange for use.

- 1 coolant temperature sensor signal (ECU 39#)
- 2 sensor signal ground (ECU 35#)
- 3 another line connects water temperature signal of gauge.

Troubleshooting: mainly check if there is short circuit or open circuit on the connection between 3 lines, ECU and gauge on sensor.

If there is short circuit, open circuit or grounding between sensor wire harnesses.

Line grounding or defect grounding is liable to cause engine water temperature gauge to indicate excessive temperature.

※**Knock Sensor KS**

Purpose: this sensor is designed to provide ECU with engine knocking information so as to carry out knocking control.

Composition and principle: knock sensor is a sort of vibration acceleration sensor, which is fixed on engine cylinder block. ECU controls engine ignition via signals detected by pressure-sensing element.

Failure diagnosis: ECU monitors on various sensors, actuators, power amplification circuits and sensing circuits. In case any of the following situations occurs, failure mark of the knock sensor is set.

- . Knock sensor failure
- . Knocking control data processing circuit failure
- . Cylinder-detecting signal is unreliable

After failure mark of knock sensor being set, knocking closed-loop control is shut down, reducing a safety angle from the ignition advance angle stored in ECU. When error frequency cuts down to below setting

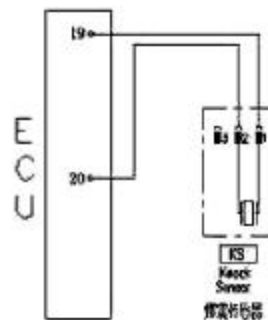
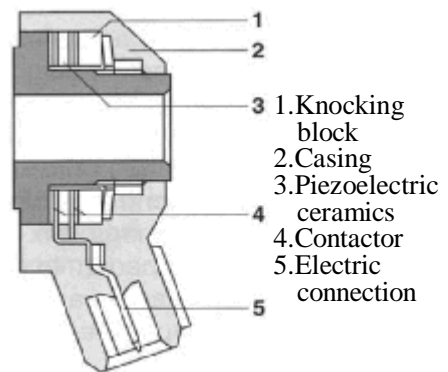

Circuit diagram of knock sensor

value, failure mark restores.

Installation hint: tightening torque is $20 \pm 5 \text{Nm}$.

Pins:

1 Knock sensor signal 1 (ECU19#)

2 Knock sensor signal 2 (ECU20#)

Troubleshooting: mainly check if there is short circuit or open circuit on the connection between 2 lines on sensor and corresponding ECU pins.

If gasket is added during installation; if tightening torque is proper.

If there is stitching defect between sensor and cylinder, or there is foreign matter between them.

※ **Oxygen Sensor**

Purpose: this sensor is designed to provide the information that if there is surplus oxygen after full combustion of fuel, which is injected into engine cylinder in the intake air. ECU, when applying this information, can carry out fuel quantitative closed-loop control so as to achieve utmost conversion and purification of the three major toxic elements (HC, CO and NOX) in the engine exhaust with the application of three-way catalytic converter.

Composition and principle: the sensing element of oxygen sensor is a porous ceramic pipe, the outer side of pipe wall is surrounded by engine exhaust, while inner side vents to atmosphere. According to inside and outside oxygen concentration difference, sensor figures out indirectly fuel injection pulse width, and then transfers the information to ECU, and the ECU controls the injection again.

The working voltage of oxygen sensor fluctuates between 0.1-0.9V, 5-8 variations in 10 seconds is required; if lower than such frequency value, it shows that the sensor is aged, and needs replacement. The said sensor is unrepairable.

Failure diagnosis: ECU monitors on various sensors, actuators, power amplification circuits and sensing circuits. In case any of the following situations occurs, failure mark of the oxygen sensor is set.

. Accumulator voltage is unreliable

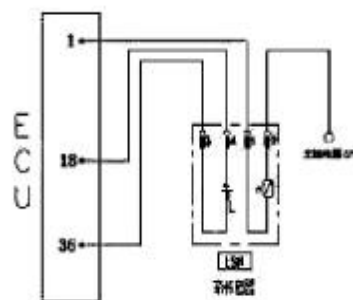

Circuit diagram of Oxygen sensor

- . Manifold absolute pressure signal is unreliable
- . Engine coolant temperature signal is unreliable.
- . Injector driver stage failure

After oxygen sensor failure mark is set, fuel quantification closed-loop control is shut down, and the primitive fuel injection time stored in ECU is used to carry out fuel quantification.

Installation hints: the tightening torque of oxygen sensor is 50-60Nm, a layer of rust preventive oil shall be applied on oxygen sensor after replacing so as to prevent from incapable removal in case of rust.



Interior structure of oxygen sensor

Troubleshooting: mainly check if the plug connection of several wires on the sensor is in good condition, and if there is short circuit or open circuit.

Generally, sensor damage is caused by plumbum and phosphorus poisoning, so pay attention to fuel quality, meanwhile excessive consumption of engine oil is Oxygen sensor has a cable, the other end of which is electric connection. The outside of sensor is wrapped with asbestos fireproof covering.

There are 4 pins on the joint:

- 1# connecting with heating control (ECU1#);
- 2# connecting with heating power and main relay;
- 3# connecting with sensor ground (ECU36#);
- 4# connecting with signal (+) (ECU18#).

※ Electronic Control Unit ECU

Purpose: ECU is the core of electronic engine control system. Sensors sent various signals to ECU for electric control, and then ECU controls operations of fuel injector and ignition coil, etc. after internal calculation, thus controlling working of engine.

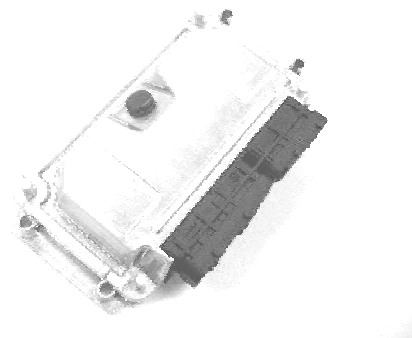

ECU

Normal operation voltage: 9-16V

Composition: it has shielded casing and printed circuit board, which integrates lots of electronic control units for the control of EFI system.

Installation: to be fixed by the support of bracket under pilot trench of front windshield. Pay attention to waterproofing.

Functions:

- Multipoint sequential injection
- Controlling ignition
- Idle speed control
- Independent knocking control on cylinder-by-cylinder basis (knock sensor KS-1);
- Providing sensors with power supply: 5V/100mA
- Adopting cylinder-detecting signal (Phase sensor PG1)
- λ closed-loop control with self-adaptation
- Controlling carbon canister control valve
- Air conditioning switch
- Engine-fault indicating lamp
- Fuel quantitative correction
- Engine speed signal output (TN signal)
- Speed signal input
- Failure self-diagnosis with flash code function
- Accepting engine load signal

Troubleshooting: due to the fact that ECU (electric control unit) has low failure rate, so generally it is not advisable to replace ECU for troubleshooting on any problem. Failure of components such as periphery circuit and sensors shall be checked and solved firstly. Do not replace ECU until all periphery components are confirmed to be fault-free.

Description of pins of ECU:

Pin	Connection point	Type	Pin	Connection point	Type
1	Heated oxygen sensor	Output	42	A/C temperature sensor	Input
2	Ignition coil 2	Output	43		
3	Ignition ground wire	Ground	44	Non-sustained power supply	Input
4			45	Non-sustained power supply	Input
5	Ignition coil 1	Output	46	Carbon canister Valve	Output

6	Fuel injector 4 (the 2 nd cylinder)	Output	47	Fuel injector 3 (the 4 th cylinder)	Output
7	Fuel injector 2 (the 3 rd cylinder)	Output	48		
8	Output of engine speed signal	Output	49		
9			50	Control of low speed fan	Output
10			51	Electronic ground 2	Ground
11			52		
12	Sustained power supply	Input	53	Electronic ground 1	Ground
13	Ignition switch	Input	54		
14	The main relay	Output	55		
15	Engine rotary sensor A	Input	56		
16	Throttle position sensor	Input	57	A/C compressor switch	Input
17	Sensor ground 1	Ground	58		
18	Oxygen sensor	Input	59	Speed signal	Input
19	Knock sensor A	Input	60		
20	Knock sensor B	Input	61	Power ground 1	Ground
22			63	Non-sustained power supply	Input
23			64	Phase angle sensor D of step motor	Output
24			65	Phase angle sensor A of step motor	Output
25			66	Phase angle sensor B of step motor	Output
26			67	Phase angle sensor C of step motor	Output
27	Fuel injector 1 (1 cylinder)	Output	68	Control of high speed fan	Output
28			69	Fuel pump relay	Output
29	Inspection light	Output	70	A/C compressor relay	Output
30			71	Diagnostic K wire	I/O
31			72		
32	5V power supply 2	Output	73		
33	5V power supply 1	Output	74		
34	Engine rotary sensor B	Input	75	A/C switch	Input
35	Sensor ground 3	Ground	76	Blaster switch	Input
36	Sensor ground connector 2	Ground	77	Headlight switch	Input
37	Air intake pressure sensor	Input	78		
38			79	Phase angle sensor	Input
39	Temperature sensor of engine coolant	Input	80	Power ground connector 2	Ground
40	Temperature sensor of air intake	Input	81		
41					

※Electrical fuel pump

Function: Supply the fuel from the fuel tank to the engine at required pressure and flow (vary from individual system).

Structure and working principle: The electrical fuel pump is comprised of direct current motor, vane pump and end cover (integrated with non-return valve, release valve and anti-electromagnetic interference elements). The pump and the motor are mounted on the same shaft and sealed in the same house. The pump and motor are surrounded by the gasoline for cooling and lubrication. The battery supplies power to the electrical fuel pump through the fuel pump relay and the pump relay switches on the circuit of the electrical fuel pump only during start-up and operation of the engine. If the engine stops running due to malfunction, the fuel pump will stop operation automatically. The maximum pressure at exit of the electrical fuel pump is determined by the release valve within the range of 450-650 kPa. However the pressure of the whole fuel system fluctuates along with fluctuation of the air intake manifold pressure. The difference between the system pressure and the air intake manifold pressure, which normally is 350kPa, is determined by the fuel pressure regulator.

Note: The temperature of fuel has a large impact on performance of the fuel pump. When running under high temperature for a long time, if the fuel temperature is higher than a certain temperature, the pressure of the fuel pump will be decreased rapidly. So please check carefully whether the performance of the fuel pump under high temperature is good if the engine fails to hot start.

Pins: The electrical fuel pump has two pins connecting to the fuel pump relay. Beside these 2 pins there are marks of “+” and “-” on the shell of the fuel pump respectively, which represent the positive and negative grid.

The 70# pin of ECU controls the fuel pump relay.



Electrical fuel pump

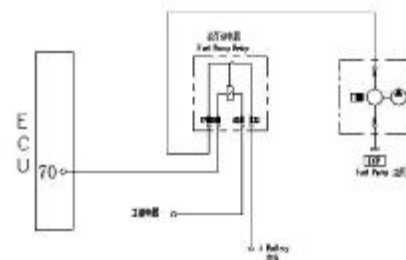

Circuit diagram of the electrical fuel

Troubleshooting: The common malfunctions of the fuel pump are representation of insufficient fuel pressure, not pumping fuel and so on. It shall be verified firstly in troubleshooting that the fuel pressure is within rated range and the pipeline is leaked. In addition both the positive and negative pressure of the fuel tank will have impacts on the fuel system.

※Solenoid fuel injector

Function: The fuel injector supplies atomized fuel to the engine through injecting the fuel within the required time according to the demand from the ECU.

Structure and working principle: The ECU sends the electrical pulse to the fuel injector coil for generate a magnetic force. If the magnetic force is increased enough to overcome the composite force of the release spring pressure force, the gravity force of needle valve, and the friction force, the needle valve will begin to rise and the fuel injection will start. The maximum lift range of the needle valve is no more than 0.1mm. When the fuel injection pulse ends, the pressure force of the release spring will make the needle valve close again.

Notes on installation: Only the specific connector can be used in the fixed fuel injector and shall not be mixed.

For the convenience of installation it is recommended that the upper O ring connected to the fuel distributor pipe shall be coated with silica-free clean oil. Pay attention not to make oil contaminate the inside of the fuel injector and the injection hole.

Place the fuel injector in the fuel injector base in vertical direction and fasten the injector on the base by the clasp.

Note: As for the car not being used for a long time, it is possible that such car can not start properly because the coagulation of fuel in the fuel injector. Under such circumstance verify carefully that the fuel injector is coagulated.

Fault diagnosis: The electrical injection system of A15 RHD car can conduct fault diagnosis on the driving stage of the fuel injector in stead of conducting fault diagnosis on its self. If the driving stage of the fuel injector is short or overloaded to the battery power supply, short to ground or open, the malfunction flag

supply, short to ground or open, the malfunction flag bit is set. The closed loop control of the oxygen sensor and its memory precontrol are disabled, but the last data stored in its memory is valid. After the malfunction is fixed, the malfunction flag bit will be reset.

Working pressure: 350 kPa

Resistance of the fuel injector: 11-16Ω

Pins: Each fuel injector has two pins. Of which the one marked by “+” is connected to the 87# pin of output terminal of the fuel pump relay; the other is connected to the 27#, 6#, 7#, or 47# pin of the ECU respectively.

Troubleshooting: The common malfunctions of the fuel injector such as unsmooth fuel injection and defective atomization are normally resulted due to long term use of the engine. So the fuel injector shall be cleaned periodically. The circuit short or open in the internal coil of the fuel injector also will result malfunction of the fuel injection system. Verify that the system circuits are short or open.

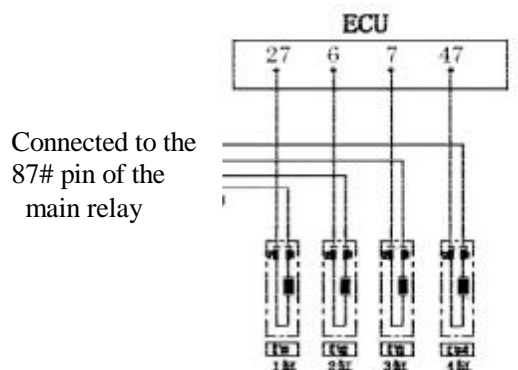

Circuit diagram of the solenoid fuel injector

※ Idle actuator with step motor DLA

Function: The idle actuator with step motor is also equipped with a bypass air intake duct. If the throttle is closed air can enter the engine through such bypass duct. The ECU can adjust the sectional area of the bypass duct through this step motor, control the air intake flow and in turn control the quantity of fuel injection based on the air flow. The increase or decrease of the engine rotary speed can be achieved through increasing or decreasing the sectional area of the bypass duct under idle speed, through which the closed loop control of engine rotary speed under idle speed is achieved eventually.



Idle actuator with step motor

Structure and working principle: The step motor is a micro-motor, which is comprised of steel stators installed in a circle and a rotor. Each steel stator has a coil. The rotor is permanent magnet and the center of the magnet is a nut. All the coils of stators are always on. If the current direction of any coil is changed, the rotor will turn by an angle. If all coils of stators change their currents directions in a proper order, a rotating magnetic field will be generated and result in the permanent magnet rotor rotating in designed direction.

Fault diagnosis: The ECU can detect the circuit short and circuit open in the two coils of the idle step motor. Upon the occurrence of such malfunction the engine malfunction alarm light will be lit and the engine will enter the malfunction operation mode.

Pins:

Pin A is connected to the 29# pin of ECU;

Pin B is connected to the 4# pin of ECU;

Pin C is connected to the 26# pin of ECU;

Pin D is connected to the 21# pin of ECU.

Troubleshooting: Verify that the four circuits between the step motor and the ECU are short or open. Verify that the step motor is jammed. Verify that there is circuit short or circuit open inside the step motor.

※ **Ignition coil ZSK-ROV**

Function: The ignition coil transforms the low voltage of the primary winding into the high voltage of the secondary winding. The spark plug generates the spark through discharging and ignites the combustion gas mixed with air and fuel.

Structure and working principle: The ignition coil is comprised of the primary winding, the secondary winding, the iron core, the shell and so on. If the battery voltage applies on the primary winding, the primary winding is charged. After the ECU cut off the circuit of the primary winding the charging will be stopped and the high voltage will be inducted in the secondary winding.

Fault diagnosis: Because the ECU is not able to conduct diagnosing for the ignition coil, there is no diagnostic trouble code for the malfunction of the ignition coil. Whether the ignition coil functions properly can be judged only by inspecting the ignition coil resistance. The ignition coil resistance can be

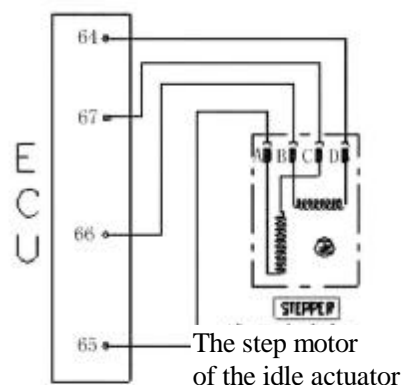

Circuit of the stepper of the idle



External appearance of

coil resistance. The ignition coil produces quite a lot of heat under normal operation and the over temperature of the ignition coil will result in such malfunctions as increase of the ignition coil's resistance, unstable operation of the engine and engine stall.

Primary winding: 0.47 ohms

Secondary winding: 8 ohms

Pins:

1# pin of the primary winding is connected to the 5# pin of ECU;

2# pin of the primary winding is connected to the 2# pin of ECU;

3# and 4# pins are jointly connected to the positive grid of power supply.

High voltage side: 1#, 2#, 3# and 4# pins are connected respectively to the spark plug of the cylinder with the same number through the distributor circuit.

Troubleshooting: Verify that there is circuit short or circuit open in the coils.

Verify that there is electrical leakage and crack on the shell.

Verify that the electricity for ignition is not sufficient due to coil ageing.

※Carbon canister control valve

Function: It is used to control the purge airflow of the carbon canister. The carbon canister control valve is controlled by the ECU through the pulse length and frequency (i.e. duty ratio) based on the engine load. The excessive accumulation of fuel vapor in the carbon canister will result in fuel spill and environment pollution, so the function of the solenoid valve of the carbon canister is to open the valve at an appropriate time so that the excessive fuel vapor can enter the air intake pipe and participate in the combustion.

Structure and working principle: The carbon canister is comprised of magnetic coil, armature, valve and other elements. There is a filter screen at its inlet. The airflow passing the carbon canister control valve is not only relative to the duty ratio of the pulse which is sent by the ECU to the carbon canister control valve, but also relative to the pressure difference between the exit and inlet of the carbon canister control valve. If there is no pulse, the carbon canister control valve is closed.

Ignition coil with double spark

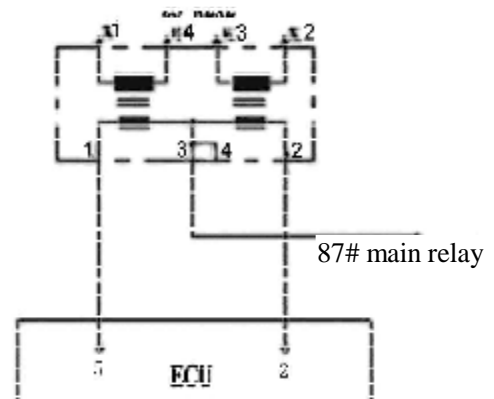

Circuit diagram of the ignition coil

The ECU can indirectly control the purge airflow through controlling the charging time of the carbon canister solenoid valve based on the signals provided by various sensors of the engine.

Fault diagnosis: The ECU doesn't have the function of self-diagnosis for the carbon canister control valve, but has the function of self-diagnosis for the driving stage of control valve of carbon canister. If the driving state of the control valve of carbon canister is short or overloaded to the battery voltage, short to ground or open, the basic memory of the closed loop control of fuel quantity will be closed, the memory of idling air demand quantity will be closed and the memory data at that time is valid. The common malfunctions of engine are unstable idling or excessive high idle speed under the malfunction of the solenoid valve of carbon canister.

Pins:

1# pin is connected to the 87# pin on output terminal of the main relay;

2# pin is connected to the 46# pin of ECU.

Troubleshooting: The blockage and crack of the carbon canister will result in the increase of air intake.

※ **Steel fuel distribution pipe assembly**

Function: Store and distribute the fuel and provide a relative stable pressure for the fuel injection system so as to achieve the uniform fuel supply pressure and quantity for each cylinder and stable operation of engine.

Structure: The fuel distribution pipe assembly is comprised of fuel distribution pipe (KVS-S) and fuel injector (EV).

Installation requirement: The connection of fuel pipe and rubber hose shall be fastened by clamp. The model of the selected clamp shall match to the rubber hose to ensure the seal connection between the fuel pipe and the rubber hose.

Fault diagnosis: There is seldom possibility for the malfunction occurrence in the main fuel supply pipe. Most of the malfunctions, which result in the leakage of the fuel system, are caused by poor assembly, so proper note shall be paid during installation that any used O-oil seal shall not be used again and appropriate lubricant is allowed to be painted during assembly.

Carbon canister control valve

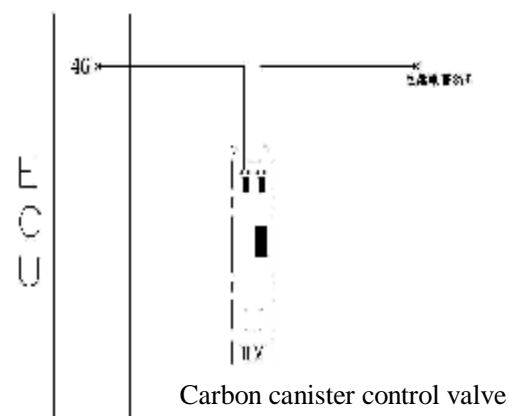

Circuit diagram of the solenoid valve of the charcoal canister TEV-2

BASIC PRINCIPLE OF FAULT DIAGNOSIS FOR ELECTRONIC FUEL INJECTION SYSTEM

• RECORD OF MALFUNCTION INFORMATION

The electronic control unit consistently monitors the operations of sensors, actuators, related circuits, malfunction alarm lights, voltage of battery and so on, even the operation of the electronic control unit itself, as well as carries out the examination on reliabilities of the signals output by the sensors, driving signals of actuators, and internal signals (such as oxygen closed loop control, knock control, idle speed control, battery voltage control and etc.). Once it is found that there is a malfunction in some chain or some signal is not reliable, the electronic control unit will set the record of malfunction information in the RAM of malfunction memory. The record of malfunction information is stored as diagnostic trouble code and displayed in the same order as the occurrence of the malfunctions.

Based on their frequency of occurrence, the malfunctions can be classified as “steady state malfunction” and “random malfunction” (such as the malfunctions caused by temporary circuit open of wiring harness or defective contact of connectors).

• MALFUNCTION STATUS

If the duration period of the identified malfunction exceeds its setting stabilizing time at the first time, ECU will regard this malfunction as a stable malfunction and store it in the memory of “steady state malfunctions”. If the malfunction disappears within its setting stabilizing time, it will be stored as “random malfunction” or “non existence”. If this malfunction is identified again, it will still be regarded as “random malfunction”, but the “existence” of historic malfunction will not influence normal operation of the engine.

• MALFUNCTION TYPES

Short to positive grid of power supply;

Short to ground;

Circuit open (if there is pull up resistance or pull down resistance in input stage, the ECU will regard the malfunction of circuit open on input terminal as the malfunction that the input terminal is short to power supply or to ground.);

Unreliable signals.

• FOUR TYPES OF MALFUNCTIONS

Maximum malfunction, the signal exceeds the upper limit of the rated range.

Minimum malfunction, the signal exceeds the lower limit of the rated range.

Signal malfunction, no signal.

Illogical malfunction, there is signal but the signal is not logical.

- **LIMP DRIVE**

If some detected important malfunctions last longer than the setting stabilizing time, ECU will take proper software measures, for example, disable some control functions including the oxygen sensor closed loop control and the like, replace some unreliable data with the setting values and etc.. Therefore even the working condition of the engine is quite bad at that time, but the car still can be driven. The objective of such measures is to drive home or drive to service station limpingly so as to avoid the embarrassment that the car has to be broken down on highway or in field. As soon as the detected malfunction disappears, the normal data will be reused.

- **MALFUNCTION ALARM**

Some cars equipped with M7.9.7 system have the malfunction alarm light. If some important components such as ECU, the air intake manifold absolute pressure sensor, the throttle position sensor, the coolant temperature sensor, the knock sensor, the oxygen sensor, the phase angle sensor, the fuel injector, two drive stages of idle actuator with step motor, the carbon canister control valve, the cooling fan relay have malfunctions, when the corresponding malfunction flag bit is set, ECU will send alarm through the malfunction alarm light until this malfunction flag bit is reset.

- **MALFUNCTION READOUT**

The malfunction information record can be called from the electronic control unit through the diagnostic tester, or be read through the flashing code. If the malfunction is related to the function of fuel air mixing ratio regulator, the corresponding malfunction information record can be read at least 4 minutes after the engine starts running.

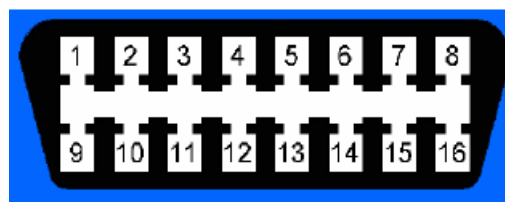

ISO 9141-2 Standard diagnostic connector

Connection to the diagnostic tester

This system adopts the “K” line communication protocol, and utilizes the ISO 9141-2 standard diagnostic connector (shown in the above figure). This standard diagnostic connector is fixed on the wiring harness of the engine. The 4#, 7#, and 16# pins of the standard connector are connected to the engine management system (EMS), the 4# pin is connected to the ground wire of the car, the 7# pin is connected to the 71# pin of ECU (i.e. the “K” line of engine data), the 16# pin is connected to the positive grid of the battery.

The detailed procedures are:

Turn on the ignition switch, but not start up the engine, ground the 7# pin of ECU by K wire for more than 2.5 seconds, then open the ground connection, after that the coding light starts flashing.

After the K wire is grounded for more than 2.5 seconds the output of flashing code is the value of P-CODE. For example, the flashing method of P0203 is: consecutive flashes of 10 times-pause-consecutive flashes of 2 times-pause,-consecutive flashes of 10 times-pause-consecutive flashes of 3 times.

• CLEARING MALFUNCTION INFORMATION RECORD

After the malfunction is fixed, the malfunction information record in the memory shall be cleared. Such malfunction information, which appeared at the time of ignition but failed to be maintained to the end of stabilizing period, will not be recorded. If the value Hz of frequency counter reaches 0, the malfunction information records in the malfunction memory will be cleared automatically. The malfunction information record will be cleared upon the demand of “clearing the malfunction memory” through the diagnostic tester. The malfunction information records in the external RAM can be cleared by disconnecting the connector of ECU or removing the wire of the battery.

• TROUBLESHOOTING:

WE ONLY CAN KNOW THE ROUGH POSITION of the malfunction whose malfunction information record is obtained through the above measures, and it doesn't mean that we have found out that malfunction exactly. Because any malfunction is possibly caused by the damage of electric components (such as sensors, actuators or ECU and the like), the circuit open, or the circuit short to ground or positive stud of battery, even the mechanical malfunctions.

The malfunction is intrinsic and its appearance is various symptoms. After the symptom is detected the diagnostic tester or the flashing code shall be used to search the malfunction information record, and excluding corresponding malfunction based on the malfunction information. And then carry out the troubleshooting based on the symptom of the engine.

DETAILED TABLE OF DIAGNOSTIC TROUBLE CODES

Diagnostic trouble code: P0107 “Undervoltage in circuit of air intake pressure sensor”

Item No.	Operation procedure	Inspection results	Follow-up procedure
1	Connect the diagnostic tester and adaptor, and turn the ignition switch to “ON” position.		Proceed to next step.
2	Observe the “air intake pressure” in data flow and verify that it is maintained at 101kPa (the exact value is determined by the atmospheric pressure at that time).	Yes	Proceed to Step 5
		No	Proceed to next step.
3	Disconnect the connector of the air intake pressure sensor on the wiring harness and inspect with multimeter to verify that the voltage between the 3# and 1# pins of the connector is about 5V.	Yes	Proceed to Step 5
		No	Proceed to next step.
4	Verify that the circuits between the 17#, 33# and 37# pins of ECU and the 1#, 3#, and 4# pins of the sensor connector are short to ground.	Yes	Repair or replace the wiring harness.
		No	Proceed to next step.
5	Start up the engine, run at idle speed. Step on the accelerator pedal slowly until the nearly full opening, observe the “air intake pressure” displayed on the diagnostic tester and verify that the value is stable without significant change; if step on the accelerator pedal quickly until nearly full opening, whether the value exceeds 90kPa instantaneously.	Yes	Refer to diagnosis help.
		No	Replace the sensor.
6	Start up the engine, run at idle speed. Observe the value of “Coolant temperature” on the diagnostic tester to verify that the indicated value is increased along with the temperature increase of the engine coolant.	Yes	Refer to diagnosis help.
		No	Replace the sensor.

Diagnostic trouble code: P0118“Over temperature indicated by engine coolant temperature sensor”

Item No.	Operation procedure	Inspection results	Follow-up procedure
1	Connect the diagnostic tester and adaptor, and turn the ignition switch to “ON” position.		Proceed to next step.
2	Observe the “coolant temperature” in data flow to verify that it matches to the engine temperature (the exact value is determined by the engine temperature at that time). Note: If the indicated value is maintained at -40℃ at that time, there may be some open malfunction occurs in the circuit.	Yes	Proceed to Step 6
		No	Proceed to next step.
3	Disconnect the connector of the coolant temperature sensor on the wiring harness, inspect with multimeter to verify that the resistance between 1# and 2# pins of the sensor matches to the temperature (see the related part of this maintenance manual for reference).	Yes	Proceed to next step.
		No	Replace the sensor.
4	Disconnect the connector of the coolant temperature sensor on the wiring harness, inspect with multimeter to verify that the voltage between 1# and 2# pins of this connector is about 5V.	Yes	Proceed to Step 6
		No	Proceed to next step.
5	Check whether the circuits between 39# and 35# pins of ECU and the 1# and 2# pins of the sensor connector are short to ground.	Yes	Repair or replace the wiring harness.
		No	Proceed to next step.
6	Start up the engine, run at idle speed. Observe the value of “Coolant temperature” on the diagnostic tester to verify that the indicated value is increased along with the temperature increase of the engine coolant.	Yes	Refer to diagnosis help.
		No	Replace the sensor.

Diagnostic trouble code: P0122 “Undervoltage in circuit for throttle position sensor”

Item No.	Operation procedure	Inspection results	Follow-up procedure
1	Connect the diagnostic tester and adaptor, and turn the ignition switch to “ON” position.		Proceed to next step.
2	Observe the item of “throttle absolute opening” in the data flow to verify that the value is maintained within 4%-10% (the exact value varies from individual auto model.)	Yes	Proceed to next step.
		No	Proceed to Step5
3	Step on the accelerator pedal slowly until full opening, observe the “absolute opening of throttle” in data flow and verify that the value is increased to 85%-95% with the increasing of the accelerator pedal opening (the exact value varies from individual auto model).	Yes	Proceed to next step.
		No	Proceed to Step 5
4	Repeat the step 3, observe the “absolute opening of throttle” in data flow to verify that there is jump during the change of the value.	Yes	Replace the sensor.
		No	Proceed to next step.
5	Disconnect the connector of the throttle position sensor on the wiring harness to verify that the circuits between 17#, 32#, and 16# pins of ECU and 1#, 2#, and 3# pins of the sensor connector are short to ground.	Yes	Repair and replace the wiring harness.
		No	Proceed to next step.
6	Inspect with multimeter to verify that the voltage between 1# and 2# pins of this connector is about 5V.	Yes	Replace the sensor.
		No	Refer to diagnosis help.

Diagnostic trouble code: P0123 “Overvoltage in circuit for throttle position sensor”

Item No.	Operation procedure	Inspection results	Follow-up procedure
1	Connect the diagnostic tester and adaptor, and turn the ignition switch to “ON” position.		Proceed to next step.
2	Observe the item of “throttle absolute opening” in the data flow to verify that the value is maintained within 4%-10% (the exact value varies from individual auto model.)	Yes	Proceed to next step.
		No	Proceed to Step5
3	Step on the accelerator pedal slowly until full opening, observe the “absolute opening of throttle” in data flow and verify that the value is increased to 85%-95% with the increasing of the accelerator pedal opening (the exact value varies from individual auto model).	Yes	Proceed to next step.
		No	Proceed to Step5
4	Repeat the step 3, observe the “absolute opening of throttle” in data flow to verify that there is jump during the change of the value.	Yes	Replace the sensor.
		No	Proceed to next step.
5	Disconnect the connector of the throttle position sensor on the wiring harness to verify that the circuits between 17#, 32#, and 16# pins of ECU and 1#, 2#, and 3# pins of the sensor connector are open or short to power supply.	Yes	Repair and replace the wiring harness.
		No	Proceed to next step.
6	Inspect with multimeter to verify that the voltage between 1# and 2# pins of this connector is about 5V.	Yes	Replace the sensor.
		No	Refer to diagnosis help.

Diagnostic trouble code: P0130 “Malfunction in signal circuit of upstream oxygen sensor”

(Note: The following diagnostic procedures are applicable only under the circumstances that the trouble code of P0135 does not appear simultaneously, in case that such trouble code appears at the same time, overhaul shall be carried out based on the following procedures after dealing with the malfunction of P0135 firstly.)

Item No.	Operation procedure	Inspection results	Follow-up procedure
1	Connect the diagnostic tester and adaptor, and turn the ignition switch to “ON” position.		Proceed to next step.
2	Start up the engine, run at idle speed until the temperature of coolant reaches the normal value. Observe the value of “Oxygen sensor voltage” on the diagnostic tester to verify that the indicated value is changed quickly within the range of 100mV – 900mV.	Yes	Refer to diagnosis help.
		No	Proceed to next step.
3	Verify that the circuits between 36# and 18# pins of ECU and A# (corresponding to grey connecting wire of the oxygen sensor) and B# (corresponding to black connecting wire of the oxygen sensor) pins of the sensor connector are short to ground.	Yes	Repair and replace the wiring harness.
		No	Proceed to next step.
4	A. Verify that there is quite serious leakage in the air intake system; B. Verify that there is blockage in the fuel injector; C. Verify that the clearance of spark plug is excessive large; D. Verify that the resistance of distributor circuit is excessive large; E. Verify that the air intake valve conduit is worn out; And etc.	Yes	Carry out service based on the diagnostic results.
		No	Refer to diagnosis help.

Diagnostic trouble code: P0132 “Overvoltage of circuit for upstream oxygen sensor”

(Note: the following diagnostic procedures are applicable only under the circumstances that the trouble code of P0135 does not appear simultaneously, in case that such trouble code appears at the same time overhaul shall be carried out based on the following procedures after dealing with the malfunction of P0135 firstly.)

Item No.	Operation procedure	Inspection results	Follow-up procedure
1	Connect the diagnostic tester and adaptor, and turn the ignition switch to “ON” position.		Proceed to next step.
2	Start up the engine, run at idle speed until the temperature of coolant reaches the normal value. Observe the value of “Oxygen sensor voltage” on the diagnostic tester to verify that the indicated value is changed quickly within the range of 100mV – 900mV.	Yes	Refer to diagnosis help.
		No	Proceed to next step.
3	Verify that the circuits between 36# and 18# pins of ECU and A# (corresponding to grey connecting wire of the oxygen sensor) and B# (corresponding to black connecting wire of the oxygen sensor) pins of the sensor connector are short to power supply.	Yes	Repair and replace the wiring harness.
		No	Refer to diagnosis help.

Diagnostic trouble code: P0134 “Signal malfunction of upstream oxygen sensor”

(Note: The following diagnostic procedures are applicable only under the circumstances that the trouble code of P0135 does not appear simultaneously, in case that such trouble code appears at the same time, overhaul shall be carried out based on the following procedures after dealing with the malfunction of P0135 firstly.)

Item No.	Operation procedure	Inspection results	Follow-up procedure
1	Connect the diagnostic tester and adaptor, and turn the ignition switch to “ON” position.		Proceed to next step.
2	Start up the engine, run at idle speed until the temperature of coolant reaches the normal value. Observe the value of “Oxygen sensor voltage” on the diagnostic tester to verify that the indicated value is changed quickly within the range of 100mV – 900mV.	Yes	Refer to diagnosis help.
		No	Proceed to next step.
3	Verify that the circuits between 36# and 18# pins of ECU and A# (corresponding to the grey connecting wire of oxygen sensor) and B# (corresponding to the black connecting wire of oxygen sensor) pins of the sensor connector are open.	Yes	Repair and replace the wiring harness.
		No	Refer to diagnosis help.

Diagnostic trouble code: P0135 “Malfunction in heating circuit of upstream oxygen sensor”

Item No.	Operation procedure	Inspection results	Follow-up procedure
1	Connect the diagnostic tester and adaptor, and turn the ignition switch to “ON” position.		Proceed to next step.
2	Disconnect the connector of the oxygen sensor on the wiring harness and inspect with multimeter to verify that the voltage between C# (corresponding to the white connecting wire of the oxygen sensor) and D# (corresponding to the white connecting wire of the oxygen sensor) pins of this connector is about 12V.	Yes	Proceed to next step.
		No	Proceed to Step4
3	Inspect with multimeter to verify that the resistance between C# (white) and D# (white) pins of the oxygen sensor is within 1~6Ω under 20°C.	Yes	Proceed to next step.
		No	Replace the sensor.
4	Verify that the 8A fuse in heating circuit of the oxygen sensor is burn out.	Yes	Replace the fuse.
		No	Proceed to next step.
5	Verify that the circuits between 1# pin of ECU, 87# pin of the main relay and C# (corresponding to white connecting wire of the oxygen sensor) and D# (corresponding to white connecting wire of the oxygen sensor) are open or short to ground or power supply.	Yes	Repair and replace the wiring harness.
		No	Refer to diagnosis help.

Diagnostic trouble code: P0171 “Self adapting of closed loop control for air fuel ratio exceeding the upper limit”

(Note: the following diagnostic procedures are applicable only under the circumstances that the trouble codes of intake air pressure sensor, carbon canister control valve, oxygen sensor and so on do not appear simultaneously, in case that such trouble codes appear at same time, overhaul shall be carried out based on the following procedures after dealing with other malfunctions firstly.)

Item No.	Operation procedure	Inspection results	Follow-up procedure
1	Connect the diagnostic tester and adaptor, and turn the ignition switch to “ON” position.		Proceed to next step.
2	Start up the engine, run at idle speed until the temperature of coolant reaches the normal value. Under the full load working condition, observe the value of “Oxygen sensor voltage” on the diagnostic tester to verify that the indicated value is maintained at 100 mV without significant change for long time under certain working conditions.	Yes	Proceed to next step.
		No	Refer to diagnosis help.
3	Connect the fuel pressure gauge to the feeding pipe of fuel supply system to observe whether the fuel pressure is maintained at 350kPa under full load working condition.	Yes	Proceed to next step.
		No	Check and repair the fuel system.
4	Verify that the circuits between 36# and 18# pins of ECU and A# (corresponding to the grey connecting wire of oxygen sensor) and B# (corresponding to the black connecting wire of oxygen sensor) pins of the sensor connector are short to ground.	Yes	Repair and replace the wiring harness.
		No	Proceed to next step.
5	A. Verify that there is quite serious leakage in the air intake system; B. Verify that there is blockage in the fuel injector; C. Verify that the clearance of spark plug is excessive large; D. Verify that the resistance of distributor circuit is excessive large; E. Verify that the valve clearance is excessive large; and etc.	Yes	Carry out service based on the diagnostic results.

Diagnostic trouble code: P0172 “Self adapting of closed loop control for air fuel ratio exceeding the lower limit”

(Note: The following diagnostic procedures are applicable only under the circumstances that the trouble codes of intake air pressure sensor, carbon canister control valve, oxygen sensor and so on do not appear simultaneously, in case that such trouble codes appear at same time, overhaul shall be carried out based on the following procedures after dealing with other malfunctions firstly.)

Item No.	Operation procedure	Inspection results	Follow-up procedure
1	Connect the diagnostic tester and adaptor, and turn the ignition switch to “ON” position.		Proceed to next step.
2	Start up the engine, run at idle speed until the temperature of coolant reaches the normal value. Under the full load working condition observe the value of “Oxygen sensor voltage” to verify that the indicated value is maintained at 900 mV without significant change for long time under certain working conditions.	Yes	Proceed to next step.
		No	Refer to diagnosis help.
3	Connect the fuel pressure gauge to the feeding pipe of fuel supply system to observe whether the fuel pressure is maintained at 350kPa under full load working condition.	Yes	Proceed to next step.
		No	Check and repair the fuel system.
4	Verify that the circuits between 36# and 18# pins of ECU and A# (corresponding to the grey connecting wire of oxygen sensor) and B# (corresponding to the black connecting wire of oxygen sensor) are short to power supply.	Yes	Repair and replace the wiring harness.
		No	Proceed to next step.
5	A. Verify that there is leakage in the fuel injector; B. Whether there is air leakage in exhaust pipe; C. Whether the ignition timing is correct; D. Whether the air intake valve conduit is worn out; E. Whether the valve clearance is excessive small; And etc.	Yes	Carry out service based on the diagnostic results.
		No	Refer to diagnosis help.

Diagnostic trouble code: P0201 “Circuit malfunction of the 1 cylinder fuel injector”

Item No.	Operation procedure	Inspection results	Follow-up procedure
1	Connect the diagnostic tester and adaptor, and turn the ignition switch to “ON” position.		Proceed to next step.
2	Disconnect the connector of the 1 cylinder fuel injector on the wiring harness, and inspect with multimeter to verify that the voltage between 1# pin of this connector and the negative grid of power supply is about 12V.	Yes	Proceed to Step 4
		No	Proceed to next step.
3	Verify that the circuit between 1# pin of the connector of the 1 cylinder fuel injector and the main relay is open, or short to ground.	Yes	Repair or replace the wiring harness.
		No	Proceed to next step.
4	Inspect with multimeter to verify that the resistance between 1# and 2# pins of the 1 cylinder fuel injector is within 11~16Ω under 20℃.	Yes	Proceed to next step.
		No	Replace the fuel injector.
5	Inspect with multimeter to verify that the voltage between the connector of the 1 cylinder fuel injector (2# pin) and the negative grid of power supply is about 3.7V.	Yes	Refer to diagnosis help.
		No	Proceed to next step.
6	Verify that the circuit between the connector of the 1 cylinder fuel injector (2# pin) and 27# pin of ECU is open or short to ground or power supply.	Yes	Repair and replace the wiring harness.
		No	Refer to diagnosis help.

Diagnostic trouble code: P0202 “Circuit malfunction of the double cylinder fuel injector”

Item No.	Operation procedure	Inspection results	Follow-up procedure
1	Connect the diagnostic tester and adaptor, and turn the ignition switch to “ON” position.		Proceed to next step.
2	Disconnect the connector of the double cylinder fuel injector on the wiring harness, and inspect with multimeter to verify that the voltage between 1# pin of this connector and the negative grid of power supply is about 12V.	Yes	Proceed to Step 4
		No	Proceed to next step.
3	Verify that the circuit between 1# pin of the connector of the double cylinder fuel injector and the main relay is open, or short to ground.	Yes	Repair and replace the wiring harness.
		No	Proceed to next step.
4	Inspect with multimeter to verify that the resistance between 1# and 2# pins of the double cylinder fuel injector is within 11~16Ω under 20°C.	Yes	Proceed to next step.
		No	Replace the fuel injector.
5	Inspect with multimeter to verify that the voltage between the connector of the double cylinder fuel injector (2# pin) and the negative grid of power supply is about 3.7V.	Yes	Refer to diagnosis help.
		No	Proceed to next step.
6	Verify that the circuit between the connector of the double cylinder fuel injector (2# pin) and 6# pin of ECU is open or short to ground or power supply.	Yes	Repair or replace the wiring harness.
		No	Refer to diagnosis help.

Diagnostic trouble code: P0203 “Circuit malfunction of the triple cylinder fuel injector”

Item No.	Operation procedure	Inspection results	Follow-up procedure
1	Connect the diagnostic tester and adaptor, and turn the ignition switch to “ON” position.		Proceed to next step.
2	Disconnect the connector of the triple cylinder fuel injector on the wiring harness, and inspect with multimeter to verify that the voltage between 1# pin of this connector and the negative grid of power supply is about 12V.	Yes	Proceed to Step 4
		No	Proceed to next step.
3	Verify that the circuit between 1# pin of the connector of the triple cylinder fuel injector and the main relay is open or short to ground.	Yes	Repair or replace the wiring harness.
		No	Proceed to next step.
4	Inspect with multimeter to verify that the resistance between 1# and 2# pins of the triple cylinder fuel injector is within 11~16Ω under 20℃.	Yes	Proceed to next step.
		No	Replace the fuel injector.
5	Inspect with multimeter to verify that the voltage between the connector of the triple cylinder fuel injector (2# pin) and the negative grid of power supply is about 3.7V.	Yes	Refer to diagnosis help.
		No	Proceed to next step.
6	Verify that the circuit between the connector of the triple cylinder fuel injector (2# pin) and 7# pin of ECU is open or short to ground or power supply.	Yes	Repair or replace the wiring harness.
		No	Refer to diagnosis help.

Diagnostic trouble code: P0204 “Circuit malfunction of the 4 cylinder fuel injector”

Item No.	Operation procedure	Inspection results	Follow-up procedure
1	Connect the diagnostic tester and adaptor, and turn the ignition switch to “ON” position.		Proceed to next step.
2	Disconnect the connector of the 4 cylinder fuel injector on the wiring harness, and inspect with multimeter to verify that the voltage between 1# pin of this connector and the negative grid of power supply is about 12V.	Yes	Proceed to Step 4
		No	Proceed to next step.
3	Verify that the circuit between 1# pin of the connector of the 4 cylinder fuel injector and the main relay is open or short to ground.	Yes	Repair or replace the wiring harness.
		No	Proceed to next step.
4	Inspect with multimeter to verify that the resistance between 1# and 2# pins of the 4 cylinder fuel injector is within 11~16Ω under 20℃.	Yes	Proceed to next step.
		No	Replace the fuel injector.
5	Inspect with multimeter to verify that the voltage between the connector of the 4 cylinder fuel injector (2# pin) and the negative grid of power supply is about 3.7V.	Yes	Refer to diagnosis help.
		No	Proceed to next step.
6	Verify that the circuit between the connector of the 4 cylinder fuel injector (2# pin) and 47# pin of ECU is open or short to ground or power supply.	Yes	Repair or replace the wiring harness.
		No	Refer to diagnosis help.

Diagnostic trouble code: P0230 “Malfunction in control circuit of fuel pump”

Item No.	Operation procedure	Inspection results	Follow-up procedure
1	Connect the diagnostic tester and adaptor, and turn the ignition switch to “OFF” position.		Proceed to next step.
2	Pull out the relay of fuel pump, turn the ignition switch to “ON” position, and verify that the voltage between the power supply terminal of fuel pump relay (i.e. 30# and 86# pin of the relay) and the negative grid of power supply is about 12V.	Yes	Proceed to Step4
		No	Proceed to next step.
3	Verify that the power supply circuit of the relay is open or short to ground.	Yes	Repair or replace the wiring harness.
		No	Proceed to Step2
4	Inspect with multimeter to verify that the voltage between the control terminal of fuel pump relay (i.e. 85# pin of the relay) and the negative grid of power supply is about 3.7V.	Yes	Replace the fuel pump relay.
		No	Proceed to next step.
5	Verify that the circuit between the control terminal of the relay (i.e. 85# pin of the relay) and 69# pin of ECU is open or short to power supply or ground.	Yes	Repair or replace the wiring harness.
		No	Refer to diagnosis help.

Diagnostic trouble code: P0325 “Malfunction in circuit of knock sensor”

Item No.	Operation procedure	Inspection results	Follow-up procedure
1	Connect the diagnostic tester and adaptor, and turn the ignition switch to “OFF” position.		Proceed to next step.
2	Disconnect the connector of knock sensor on the wiring harness, inspect with multimeter to verify that the resistance between 1# pin and 2# pin of this sensor is higher than 1MΩ.	Yes	Proceed to next step.
		No	Replace the sensor.
3	Verify that the circuits between 1# and 2# pin of the knock sensor connector and 19# and 20# pins of ECU are open, or are short to ground or power supply.	Yes	Repair or replace the wiring harness.
		No	Proceed to next step.
4	Replace the knock sensor complying with the operation instructions, trial run and make the rotary speed of engine exceed 2200 rpm. Verify that the diagnostic code of P0325 appears again.	Yes	Refer to diagnosis help.
		No	Verify that it is a random malfunction.

Diagnostic trouble code: P0335 “Signal malfunction of crankshaft position sensor”

Item No.	Operation procedure	Inspection results	Follow-up procedure
1	Connect the diagnostic tester and adaptor, and turn the ignition switch to “OFF” position.		Proceed to next step.
2	Disconnect the connector of rotary sensor on the wiring harness, inspect with multimeter to verify that the resistance between 2# pin and 3# pin of this rotary sensor is about 770~950Ω under 20°C.	Yes	Proceed to next step.
		No	Replace the sensor.
3	Verify that the circuits between 2# and 3# pin of the rotary sensor connector and 34# and 15# pins of ECU are open, or are short to ground or power supply.	Yes	Repair or replace the wiring harness.
		No	Proceed to next step.
4	Verify that the signal panel of flywheel is in good condition.	Yes	Refer to diagnosis help.
		No	Replace the signal panel.

Diagnostic trouble code: P0336 “Malfunction of improper signal of crankshaft position sensor”

Item No.	Operation procedure	Inspection results	Follow-up procedure
1	Connect the diagnostic tester and adaptor, and turn the ignition switch to “OFF” position.		Proceed to next step.
2	Disconnect the connector of rotary sensor on the wiring harness, inspect with multimeter to verify that the resistance between 2# pin and 3# pin of this rotary sensor is about 770~950Ω under 20°C.	Yes	Proceed to next step.
		No	Replace the sensor.
3	Verify that the circuits between 2# and 3# pin of the rotary sensor connector and 34# and 15# pins of ECU are open, or are short to ground or power supply.	Yes	Repair and replace the wiring harness.
		No	Proceed to next step.
4	Verify that the signal panel of flywheel is in good condition.	Yes	Refer to diagnosis help.
		No	Replace the signal panel.

Diagnostic trouble code: P0340 “Malfunction of phase angle sensor signal”

Item No.	Operation procedure	Inspection results	Follow-up procedure
1	Connect the diagnostic tester and adaptor, and turn the ignition switch to “ON” position.		Proceed to next step.
2	Disconnect the connector of phase angle sensor on the wiring harness, inspect with multimeter to verify that the voltage between 1# pin and 3# pin of this phase angle sensor connector is about 12V.	Yes	Proceed to Step 4
		No	Proceed to next step.
3	Verify that the circuit between 3# pin of phase angle sensor and 87# pin of the main relay is open or short to ground; Verify that 1# pin of phase angle sensor is grounded properly.	Yes	Repair or replace the wiring harness.
		No	Proceed to next step.
4	Verify that the voltage between 2# pin of the phase angle sensor connector and the negative grid of power supply is about 9.9V.	Yes	Proceed to Step 6
		No	Proceed to next step.
5	Verify that the circuit between 2# pin of the phase angle sensor connector and 79# pin of ECU is open, or is short to ground or power supply.	Yes	Repair or replace the wiring harness.
		No	Proceed to next step.
6	Verify that the signal panel of camshaft is in good condition.	Yes	Refer to diagnosis help.
		No	Replace the signal panel.

Diagnostic trouble code: P0443 “Malfunction in control circuit of drive stage of carbon canister control valve”

Item No.	Operation procedure	Inspection results	Follow-up procedure
1	Connect the diagnostic tester and adaptor, and turn the ignition switch to “ON” position.		Proceed to next step.
2	Disconnect the connector of carbon canister control valve on the wiring harness, inspect with multimeter to verify that the voltage between 1# pin of this connector and the negative grid of power supply is about 12V.	Yes	Proceed to Step 4
		No	Proceed to next step.
3	Verify that the power supply circuit of carbon canister control valve is open or short to ground.	Yes	Repair or replace the wiring harness.
		No	Proceed to Step 2
4	Inspect with multimeter to verify that the resistance between 1# and 2# pins of carbon canister control valve is within 22-30Ω under 20°C.	Yes	Proceed to next step.
		No	Replace the control valve.
5	Inspect with multimeter to verify that the voltage between 1# pin of carbon canister control valve connector and the negative grid of power supply is about 3.7V.	Yes	Refer to diagnosis help.
		No	Proceed to next step.
6	Verify that the circuit between 2# pin of carbon canister control valve connector and 46# pin of ECU is open.	Yes	Repair or replace the wiring harness.
		No	Refer to diagnosis help.

Diagnostic trouble code: P0444 “Undervoltage in control circuit of drive stage of carbon canister control valve”

Item No.	Operation procedure	Inspection results	Follow-up procedure
1	Connect the diagnostic tester and adaptor, and turn the ignition switch to “ON” position.		Proceed to next step.
2	Disconnect the connector of carbon canister control valve on the wiring harness, inspect with multimeter to verify that the voltage between 1# pin of this connector and the negative grid of power supply is about 12V.	Yes	Proceed to Step 4
		No	Proceed to next step.
3	Verify that the power supply circuit of carbon canister control valve is open or short to ground.	Yes	Repair or replace the wiring harness.
		No	Proceed to Step 2
4	Inspect with multimeter to verify that the resistance between 1# and 2# pins of carbon canister control valve is within 22-30Ω under 20°C.	Yes	Proceed to next step.
		No	Replace the control valve.
5	Inspect with multimeter to verify that the voltage between 1# pin of carbon canister control valve connector and the negative grid of power supply is about 3.7V.	Yes	Refer to diagnosis help.
		No	Proceed to next step.
6	Verify that the circuit between 2# pin of carbon canister control valve connector and 46# pin of ECU is short to ground.	Yes	Repair or replace the wiring harness.
		No	Refer to diagnosis help.

Diagnostic trouble code: P0445 “Overvoltage in control circuit of drive stage of carbon canister control valve”

Item No.	Operation procedure	Inspection results	Follow-up procedure
1	Connect the diagnostic tester and adaptor, and turn the ignition switch to “ON” position.		Proceed to next step.
2	Disconnect the connector of carbon canister control valve on the wiring harness, inspect with multimeter to verify that the voltage between 1# pin of this connector and the negative grid of power supply is about 12V.	Yes	Proceed to Step 4
		No	Proceed to next step.
3	Verify that the power supply circuit of carbon canister control valve is open or short to ground.	Yes	Repair and replace the wiring harness.
		No	Proceed to Step 2
4	Inspect with multimeter to verify that the resistance between 1# and 2# pins of carbon canister control valve is within 22-30Ω under 20°C.	Yes	Proceed to next step.
		No	Replace the control valve.
5	Inspect with multimeter to verify that the voltage between 1# pin of carbon canister control valve connector and the negative grid of power supply is about 3.7V.	Yes	Refer to diagnosis help.
		No	Proceed to next step.
6	Verify that the circuit between 2# pin of carbon canister control valve connector and 46# pin of ECU is short to power supply.	Yes	Repair or replace the wiring harness.
		No	Refer to diagnosis help.

Diagnostic trouble code: P0480 “Malfunction in control circuit of relay of A/C condenser fan A”

Item No.	Operation procedure	Inspection results	Follow-up procedure
1	Connect the diagnostic tester and adaptor, and turn the ignition switch to “OFF” position.		Proceed to next step.
2	Pull out the relay of A/C condenser fan, turn the ignition switch to “ON” position and verify that the voltage between the power supply terminal of the relay (i.e. 30# and 85# pins of the relay) and the negative grid of power supply is about 12V.	Yes	Proceed to Step 4
		No	Proceed to next step.
3	Verify that the power supply circuit of the relay of A/C condenser fan is open or short to ground.	Yes	Repair or replace the wiring harness.
		No	Proceed to Step 2
4	Inspect with multimeter to verify that the voltage between the control terminal of relay of A/C condenser fan (i.e. 86# pin of the relay) and the negative grid of power supply is about 3.7V.	Yes	Replace the relay.
		No	Proceed to next step.
5	Verify that the circuit between the control terminal of relay (i.e. 86# pin of the relay) and 50# pin of ECU is open, or is short to power supply or to ground.	Yes	Repair or replace the wiring harness.
		No	Refer to diagnosis help.

Diagnostic trouble code: P0481 “Malfunction in control circuit of relay of A/C condenser fan B”

Item No.	Operation procedure	Inspection results	Follow-up procedure
1	Connect the diagnostic tester and adaptor, and turn the ignition switch to “OFF” position.		Proceed to next step.
2	Pull out the relay of A/C condenser fan, turn the ignition switch to “ON” position and verify that the voltage between the power supply terminal of the relay (i.e. 30# and 85# pins of the relay) and the negative grid of power supply is about 12V.	Yes	Proceed to Step 4
		No	Proceed to next step.
3	Verify that the power supply circuit of the relay of A/C condenser fan is open or short to ground.	Yes	Repair or replace the wiring harness.
		No	Proceed to Step 2
4	Inspect with multimeter to verify that the voltage between the control terminal of relay of A/C condenser fan (i.e. 86# pin of the relay) and the negative grid of power supply is about 3.7V.	Yes	Replace the relay.
		No	Proceed to next step.
5	Verify that the circuit between the control terminal of relay (i.e. 86# pin of the relay) and 68# pin of ECU is open or is short to power supply or to ground.	Yes	Repair or replace the wiring harness.
		No	Refer to diagnosis help.

Diagnostic trouble code: P0500 “Malfunction of improper speed signal”

Item No.	Operation procedure	Inspection results	Follow-up procedure
1	Connect the diagnostic tester and adaptor, and turn the ignition switch to “OFF” position.		Proceed to next step.
2	For the vehicles equipped with ABS system, verify that there is a diagnostic trouble code designed for ABS system.	Yes	Check and service the ABS system.
		No	Proceed to next step.
3	Verify that the indicating needle of speedometer works properly.	Yes	Proceed to next step.
		No	Check and service the instrument circuit.
4	Verify that the speed sensor works properly.	Yes	Proceed to next step.
		No	Replace the speed sensor.
5	Verify that the circuit between the signal cable of speed sensor and 59# pin of ECU is open, or is short to power supply or to ground.	Yes	Repair or replace the wiring harness.
		No	Refer to diagnosis help.

Diagnostic trouble code: P0506 “Idle speed lower than nominal idle speed”

Item No.	Operation procedure	Inspection results	Follow-up procedure
1	Connect the diagnostic tester and adaptor, and turn the ignition switch to “OFF” position.		Proceed to next step.
2	Verify that the adjusting screw of throttle, accelerator pedal stay and working condition of throttle are in good condition.	Yes	Proceed to next step.
		No	Carry out necessary Overhaul.
3	Verify that the working condition of idle speed regulator is correct.	Yes	Proceed to next step.
		No	Carry out necessary Overhaul.
4	A. Verify that there is under pressure in the fuel supplying system; B. Verify that there is blockage in the fuel injector; C. Verify that there is blockage in the exhaust system.	Yes	Carry out necessary Overhaul.
		No	Refer to diagnosis help.

Diagnostic trouble code: P0507 “Idle speed higher than nominal idle speed”

Item No.	Operation procedure	Inspection results	Follow-up procedure
1	Connect the diagnostic tester and adaptor, and turn the ignition switch to “OFF” position.		Proceed to next step.
2	Verify that the adjusting screw of throttle, accelerator pedal stay and working condition of throttle are in good condition.	Yes	Proceed to next step.
		No	Carry out necessary Overhaul.
3	Verify that the working condition of idle speed regulator is correct.	Yes	Proceed to next step.
		No	Carry out necessary Overhaul.
4	A. Verify that there is air leakage in the system; B. Verify that there is leakage in the fuel injector; C. Verify that there is over pressure in the fuel supplying system.	Yes	Carry out necessary Overhaul.
		No	Refer to diagnosis help.

Diagnostic trouble code: P0508 “Undervoltage in control circuit of idle speed regulator”

Item No.	Operation procedure	Inspection results	Follow-up procedure
1	Connect the diagnostic tester and adaptor, and turn the ignition switch to “ON” position.		Proceed to next step
2	Disconnect the connector of idle speed regulator and inspect with multimeter to verify that the resistances between pin A and D, pin B and C are $53\pm 5.3\Omega$ under 20°C .	Yes	Proceed to next step
		No	Replace the step motor.
3	Verify that the circuits between pin A, B, C, and D of idle speed regulator and 65#, 66#, 67#, and 64# pin of ECU are short to ground.	Yes	Repair or replace the wiring harness.
		No	Refer to diagnosis help.

Diagnostic trouble code: P0509 “Overvoltage in control circuit of idle speed regulator”

Item No.	Operation procedure	Inspection results	Follow-up procedure
1	Connect the diagnostic tester and adaptor, and turn the ignition switch to “ON” position.		Proceed to next step
2	Disconnect the connector of idle speed regulator and inspect with multimeter to verify that the resistances between pin A and D, pin B and C are $53\pm 5.3\Omega$ under 20°C .	Yes	Proceed to next step
		No	Replace the step motor.
3	Verify that the circuits between pin A, B, C, and D of idle speed regulator and 65#, 66#, 67#, and 64# pin of ECU are short to power supply.	Yes	Repair or replace the wiring harness.
		No	Refer to diagnosis help.

Diagnostic trouble code: P0511 “Malfunction in control circuit of idle speed regulator”

Item No.	Operation procedure	Inspection results	Follow-up procedure
1	Connect the diagnostic tester and adaptor, and turn the ignition switch to “ON” position.		Proceed to next step.
2	Disconnect the connector of idle speed regulator and inspect with multimeter to verify that the resistances between pin A and D, pin B and C are $53\pm 5.3\Omega$ under 20°C .	Yes	Proceed to next step.
		No	Replace the step motor.
3	Verify that the circuits between pin A, B, C, and D of idle speed regulator and 65#, 66#, 67#, and 64# pin of ECU are open.	Yes	Repair or replace the wiring harness.
		No	Refer to diagnosis help.

Diagnostic trouble code: P0560 “Improper voltage signal of system”

Item No.	Operation procedure	Inspection results	Follow-up procedure
1	Connect the diagnostic tester and adaptor, and turn the ignition switch to “OFF” position.		Proceed to next step
2	Inspect with multimeter to verify that the voltage of battery is about 12V.	Yes	Proceed to next step.
		No	Replace the battery.
3	Verify that the resistances between the 44#, 45#, and 63# pins of ECU and 87# pin of the main relay are open or short to ground.	Yes	Repair or replace the wiring harness.
		No	Proceed to next step
4	Start up the engine, and verify that the charging voltage of generator is maintained within 9-16V under different speeds.	Yes	Proceed to next step
		No	Replace the generator.
5	Verify that the earth point of engine wiring harness is correct.	Yes	Refer to diagnosis help.
		No	Repair or replace the wiring harness.

Diagnostic trouble code: P0562 “Undervoltage of system”

Item No.	Operation procedure	Inspection results	Follow-up procedure
1	Connect the diagnostic tester and adaptor, and turn the ignition switch to “OFF” position.		Proceed to next step
2	Inspect with multimeter to verify that the voltage of battery is about 12V.	Yes	Proceed to next step.
		No	Replace the battery.
3	Verify that the resistances between the 44#, 45#, and 63# pins of ECU and 87# pin of the main relay are excessive.	Yes	Repair or replace the wiring harness.
		No	Proceed to next step
4	Start up the engine, and verify that the charging voltage of generator is maintained within 9-16V under different speeds.	Yes	Proceed to next step
		No	Replace the generator.
5	Verify that the earth point of engine wiring harness is correct.	Yes	Refer to diagnosis help.
		No	Repair or replace the wiring harness.

Diagnostic trouble code: P0563 “Overvoltage of system”

Item No.	Operation procedure	Inspection results	Follow-up procedure
1	Connect the diagnostic tester and adaptor and turn the ignition switch to “OFF” position.		Proceed to next step
2	Inspect with multimeter to verify that the voltage of battery is about 12V.	Yes	Proceed to next step
		No	Replace the battery.
3	Start up the engine, and verify that the charging voltage of generator is maintained within 9-16V under different speeds.	Yes	Proceed to next step
		No	Replace the generator.
4	Verify that the earth point of engine wiring harness is correct.	Yes	Refer to diagnosis help.
		No	Repair or replace the wiring harness.

Diagnostic trouble code: P0601 “Malfunction of non-programmed check code in electronic control unit”

Item No.	Operation procedure	Inspection results	Follow-up procedure
1	Connect the diagnostic tester and adaptor and turn the ignition switch to “ON” position.		Proceed to next step
2	Clear the diagnostic trouble code and reconfirm that this malfunction is a steady state malfunction.	Yes	Proceed to next step
		No	Normal operation
3	Replace ECU.	End	

Diagnostic trouble code: P0602 “Malfunction of non-programmed diagnostic trouble code in electronic control unit”

Item No.	Operation procedure	Inspection results	Follow-up procedure
1	Connect the diagnostic tester and adaptor and turn the ignition switch to “ON” position.		Proceed to next step
2	Clear the diagnostic trouble code and reconfirm that this malfunction is a steady state malfunction.	Yes	Proceed to next step
		No	Normal operation
3	Replace ECU.	End	

Diagnostic trouble code: P0645 “Malfunction in control circuit of A/C compressor relay”

Item No.	Operation procedure	Inspection results	Follow-up procedure
1	Connect the diagnostic tester and adaptor and turn the ignition switch to “OFF” position.		Proceed to next step
2	Pull out the A/C compressor relay, turn the ignition switch to “ON” position and check if the voltage between the power supply terminal of relay (i.e. 30# and 85# pins of the relay) and the negative grid of power supply is about 12V.	Yes	Proceed to step 4
		No	Proceed to next step
3	Check if the power supply circuit of relay is open or short to ground.	Yes	Repair or replace the wiring harness.
		No	Proceed to Step 2
4	Inspect with multimeter to check if the voltage between the control terminal of A/C compressor relay (i.e. 86# pin of the relay) and the negative grid of power supply is about 3.7V.	Yes	Replace the relay.
		No	Proceed to next step
5	Check if the circuit between the control terminal of A/C compressor relay (i.e. 86# pin of the relay) and 70# pin of ECU is open.	Yes	Repair or replace the wiring harness.
		No	Refer to diagnosis help.

Diagnostic trouble code: P0646 “Undervoltage in control circuit of A/C compressor relay”

Item No.	Operation procedure	Inspection results	Follow-up procedure
1	Connect the diagnostic tester and adaptor and turn the ignition switch to “OFF” position.		Proceed to next step
2	Pull out the A/C compressor relay, turn the ignition switch to “ON” position and check if the voltage between the power supply terminal of relay (i.e. 30# and 85# pins of the relay) and the negative grid of power supply is about 12V.	Yes	Proceed to Step 4
		No	Proceed to next step
3	Check if the power supply circuit of relay is open or short to ground.	Yes	Repair or replace the wiring harness.
		No	Proceed to Step 2
4	Inspect with multimeter to check if the voltage between the control terminal of A/C compressor relay (i.e. 86# pin of the relay) and the negative grid of power supply is about 3.7V.	Yes	Replace the relay.
		No	Proceed to next step
5	Check if the circuit between the control terminal of A/C compressor relay (i.e. 86# pin of the relay) and 70# pin of ECU is short to ground.	Yes	Repair or replace the wiring harness.
		No	Refer to diagnosis help.

Diagnostic trouble code: P0647 “Overvoltage in control circuit of A/C compressor relay”

Item No.	Operation procedure	Inspection results	Follow-up procedure
1	Connect the diagnostic tester and adaptor and turn the ignition switch to “OFF” position.		Proceed to next step
2	Pull out the A/C relay, turn the ignition switch to “ON” position and check if the voltage between the power supply terminal of relay (i.e. 30# and 85# pins of the relay) and the negative grid of power supply is about 12V.	Yes	Proceed to Step 4
		No	Proceed to next step.
3	Check if the power supply circuit of relay is open or short to ground.	Yes	Repair or replace the wiring harness
		No	Proceed to Step 2
4	Inspect with multimeter to check if the voltage between the control terminal of A/C compressor relay (i.e. 86# pin of the relay) and the negative grid of power supply is about 3.7V.	Yes	Replace the relay
		No	Proceed to next step
5	Check if the circuit between the control terminal of A/C compressor relay (i.e. 86# pin of the relay) and 70# pin of ECU is short to supply.	Yes	Repair or replace the wiring harness
		No	Refer to diagnosis help

Diagnostic trouble code: P1651 “Malfunction in control circuit of malfunction alarm light”

Item No.	Operation procedure	Inspection results	Follow-up procedure
1	Connect diagnostic tester and adaptor, and turn the ignition switch to “ON” position.		Proceed to next step
2	Check the action of engine malfunction alarm light by using the “actuator action testing” function of diagnostic tester and observe whether the light is always on or off.	Yes	Proceed to next step
		No	Normal operation
3	Verify that the supply circuit of engine malfunction alarm light is open or short to ground.	Yes	Repair or replace the wiring harness.
		No	Proceed to next step
4	Check if the supply circuit between the control terminal pin of engine malfunction alarm light and 29# pin of ECU is open, or is short to ground or power supply.	Yes	Repair or replace the wiring harness.
		No	Refer to diagnosis help.

PROCEDURES FOR FAULT DIAGNOSIS ACCORDING TO THE SYMPTOMS OF THE ENGINE

A preliminary inspection should be carried out before implementing the steps of fault diagnosis according to the symptoms of engine:

- (1) Verify that there is no abnormal behavior with the ECU and malfunction indicator light (not applicable for car models without setting of malfunction indicator light).
- (2) Inspect with the diagnostic tester or flashing light to verify that there is no malfunction information record.
- (3) Inspect the idle speed data of warmed up engine in the electronic control system with the diagnostic tester and verify that they are normal.
- (4) Verify that the malfunction symptom complained by the car owner exists and locate the exact position of the symptom.

Then carry out the visual inspection: Verify that the grounding point of the wiring harness is clean and firm.

Verify that the vacuum pipelines have any ruptures or twists together, and whether its connections are correct.

Verify that the pipeline has any symptom of blockage.

Verify that the air inlet pipeline is flattened or damaged.

Verify that the sealing between the throttle body and the air intake manifold is in a good condition.

Verify that the high voltage cable of ignition system has any rupture or ageing, and whether the wire routing is correct.

Verify that the connection of conducting wire is correct and whether the connector is loose or poorly contacted.

1) The engine is not running or running slowly during starting

Item	Operation procedure	Inspection results	Follow-up procedure
1	Inspect with multimeter to see whether there is a voltage of about 10-12.5V between two battery terminals.	Yes	Proceed to next step
		No	Repair or replace the battery
2	Turn the ignition switch to "ON" position. Inspect with multimeter to see whether there is a voltage of about 10-12.5V between the terminals connecting the ignition switch and the positive grid of the battery.	Yes	Proceed to next step.
		No	Repair the terminal or replace the conducting wire
3	Keep the ignition switch at the startup position and inspect with multimeter to see whether that there is a voltage of more than 8V between the terminals connecting the ignition switch and the starting motor magnetic clutch.	Yes	Proceed to next step.
		No	Repair or replace the ignition switch
4	Inspect with multimeter to see whether the starting motor has any open or short-circuit.	Yes	Repair or replace the starting motor
		No	Proceed to next step.
5	Verify that the engine is jammed due to poor lubricating.	Yes	Fix the malfunction
		No	Proceed to next step.
6	In case of winter season, inspect to see whether there is too much friction in the starting motor due to the improper selection of engine lubricating oil and gearbox oil.	Yes	Replace with appropriate lubricating oil
		No	Inspect other items

2) The engine can run but cannot successfully start up during starting

Item No.	Operation procedure	Inspection results	Follow-up procedure
1	Turn the ignition switch to “ON” position. Inspect with the diagnostic tester to see whether there is any malfunction information record.	Yes	Fix the indicated malfunction
		No	Proceed to next step.
2	Disconnect the cylinder distribution wire and connect it to the spark plugs, make a space of 5-10mm between the grid of the spark plug and engine body. Then turn on the engine with starting motor, verify that there is any bluish-white high-voltage spark.	Yes	Proceed to Step 8.
		No	Proceed to next step.
3	Verify that the resistance of the high voltage cable is normal	Yes	Proceed to next step.
		No	Repair or replace high voltage cable
4	Verify that the cylinder-distribution high voltage cable and spark plug have any damage.	Yes	Replace
		No	Proceed to next step.
5	Verify that the cylinder identification rotor ring in distributor is loose or damaged.	Yes	Replace
		No	Proceed to next step.
6	Verify that the ignition coil is normal	Yes	Proceed to next step.
		No	Replace
7	Verify that the plug in connector of the camshaft is properly connected.	Yes	Proceed to next step.
		No	Connect the connector properly
8	Turn the ignition switch to “ON” position. Verify that the fuel pump relay and fuel pump is functional.	Yes	Proceed to next step.
		No	Service the fuel pump circuit
9	Connect it to the fuel manometer valve. Make the 30# and 87# pins of fuel pump relay short so as to operate the fuel pump, and then verify that the fuel pressure is maintained at about 350kPa.	Yes	Proceed to next step.
		No	Proceed to Step 13.
10	Pull out the fuel distributing pipe together with the fuel injector and disconnect the fuel injector connectors on the wiring harness one by one. Connect a 12V supply directly from the battery to the fuel injector and verify that the fuel injector is functioning.	Yes	Proceed to Step 12.
		No	Proceed to next step.
11	After washing and cleaning the fuel injector, verify that it is capable of injecting fuel again.	Yes	Proceed to next step.
		No	Replace the fuel injector

12	Verify that the fuel is deteriorated or contaminated by water.	Yes	Replace the fuel
		No	Proceed to Step 18.
13	Verify that the fuel pressure is lower than 350kPa.	Yes	Proceed to next step.
		No	Proceed to Step 17.
14	Close the fuel manometer valve. Connect the ignition switch again to re-operate the fuel pump in order to verify that the fuel pressure can be established.	Yes	Proceed to next step.
		No	Proceed to Step 16.
15	Open the fuel manometer valve and clamp the fuel return pipe with the fuel tube clamp to stop the fuel return in order to verify that the fuel pressure can be established quickly.	Yes	Replace fuel and pressure regulator
		No	Repair or replace the fuel injector or fuel pipe
16	Verify that the fuel inlet pipe has any leakage or blockage.	Yes	Repair or replace the fuel inlet pipe
		No	Replace the fuel pump
17	Verify that the fuel return pipe has any leakage or bending.	Yes	Repair or replace the fuel return pipe
		No	Replace the fuel pressure regulator
18	Connect an adapter between ECU and the wiring harness. Then verify that there is any voltage at the ECU's pin No.44, 45, 63, 12 and 13, and to see whether the positive power supply wires connected to the above ECU's pins and the ground wires connected to the pin No. 3, 51, 53, 61 and 80 are normal.	Yes	Proceed to next step.
		No	Repair or replace the wiring harness.
19	Verify that the parts of air intake system have any air leakage.	Yes	Repair
		No	Proceed to next step.
20	Verify that the absolute pressure and temperature sensor of air intake manifold has any blockage.	Yes	Repair or replace
		No	Proceed to next step.
21	Verify that the coolant temperature sensor is normal.	Yes	Proceed to next step.
		No	Repair or replace
22	Verify that the unsuccessful startup is due to mechanical reasons such as excessive clearance between the piston and cylinder or due to cylinder air leakage, etc.	Yes	Fix the mechanical malfunction
		No	Replace the ECU

3) Difficult start-up of hot engine

Item No.	Operation procedure	Inspection results	Follow-up procedure
1	Turn the ignition switch to “ON” position. Inspect with the diagnostic tester to see whether there is any malfunction information record.	Yes	Fix the indicated malfunction
		No	Proceed to next step.
2	Connect the fuel manometer valve. Short the 30# and 87# pins of the fuel pump relay to operate the fuel pump in order to verify that the fuel pressure is maintained at about 350kPa.	Yes	Proceed to next step.
		No	Proceed to Step 9.
3	Disconnect the connecting fuel pipe and turn off the ignition switch. After 1 hour, verify that the pressure of fuel system is maintained between 250-300 kPa.	Yes	Proceed to next step.
		No	Repair the leakage of fuel system
4	Connect the connecting fuel pipe and block the fuel return pipe with the fuel tube clamp as well as close the fuel manometer valve. Then turn off the ignition switch, after 1 hour, verify that the pressure of fuel system is maintained between 250-300 kPa.	Yes	Replace the fuel pressure regulator
		No	Proceed to next step.
5	Verify that the fuel injector and fuel pipe have any fuel leakages.	Yes	Replace the fuel injector and fuel pipe
		No	Proceed to next step.
6	Disconnect the connector of water temperature sensor to start up the engine. Observe whether it can successfully start up.	Yes	Inspect the coolant temperature and circuit
		No	Proceed to next step.
7	Put adaptor between ECU and wiring harness. Then verify that there is any voltage at the ECU’s 44#, 45#, 63#, 12# and 13# pins and to see whether the positive power wires connected to the above ECU’s pins and the ground wire connected to the pins of 3#, 51#, 53#, 61# and 80# are normal.	Yes	Proceed to next step.
		No	Repair or replace the wiring harness

8	Replace the fuel and try the hot start again. Observe whether it can successfully start up.	Yes	End
		No	Replace the ECU
		No	Repair or replace
9	Verify that the fuel pipe has any blockage or bending and to see whether the pressure regulating valve functions of fuel pump is normally.	Yes	Proceed to next step.
		No	Repair or replace
10	Inspect with multimeter to see whether there is a voltage between two terminals of the plug in connector of fuel pump.	Yes	Proceed to next step.
		No	Repair or replace fuel pump relay and wire
11	Inspect with multimeter to see whether the resistance of fuel pump is correct.	Yes	Proceed to next step.
		No	Replace the fuel pump
12	Verify that the fuel pump is jammed.	Yes	Replace the fuel pump
		No	Replace the ECU

4) Difficult start-up under normal engine speed

Item No.	Operation procedure	Inspection results	Follow-up procedure
1	Turn the ignition switch to “ON” position. Inspect with the diagnostic tester to see whether there is any malfunction information record.	Yes	Fix the indicated malfunction
		No	Proceed to next step.
2	Verify that the air filter is free of any blockage.	Yes	Proceed to next step.
		No	Replace
3	After start up, verify that the air intake manifold pressure is maintained between 35-65 kPa at idle speed.	Yes	Proceed to next step.
		No	Fix the leakage of air intake system
4	Step on the throttle gently and observe whether it’s easy to start up.	Yes	Replace and inspect the throttle valve and idle speed passage
5	Connect the fuel manometer valve. Short the 30# and 87# pins of the fuel pump relay to operate the fuel pump in order to verify that the fuel pressure is maintained at about 350kPa.	Yes	Proceed to next step.
		No	Proceed to Step 9
6	Apply a voltage supply of 12V directly between the battery and the fuel injector with special connector, and verify that the fuel injector functions normally.	Yes	Proceed to Step 8
		No	Proceed to next step.
7	After washing and cleaning the fuel injector, verify that its function is normal.	Yes	Proceed to next step.
		No	Replace the fuel injector
8	Replace the fuel and verify that the fuel is deteriorated or contaminated by water.	Yes	Replace the fuel
		No	Proceed to Step 14
9	Verify that the fuel pressure is lower than 350kPa.	Yes	Proceed to next step.
		No	Proceed to Step 13
10	Close the fuel manometer valve. Connect the ignition switch again to re-operate the fuel pump in order to verify that the fuel pressure can be established.	Yes	Proceed to next step.
		No	Proceed to Step 12.
11	Open the fuel manometer valve and clamp the fuel return pipe with the fuel tube clamp to stop the fuel return in order to verify that the fuel pressure can be established quickly.	Yes	Replace fuel pressure regulator
		No	Repair or replace the fuel injector or the fuel pipe
12	Verify that the fuel inlet pipe has any leakage or blockage.	Yes	Repair or replace the fuel air inlet pipe

		No	Replace the fuel pump
13	Verify that the fuel return pipe has any leakage or bending.	Yes	Repair or replace the fuel return pipe
		No	Replace the fuel pressure regulator
14	Disconnect the connector of idle speed actuator before the temperature of engine coolant reaches 35 ⁰ C in order to observe whether the engine speed is decreasing.	Yes	Proceed to next step.
		No	Repair or replace the idle speed actuator
15	Turn the ignition switch to “ON” position. verify that the voltages at following ECU pins are normal: 13# is at about 12V of battery voltage; 80# and 61# are at zero.	Yes	Proceed to next step.
		No	Inspect the wiring harness and plug in connector
16	Run the engine at idle speed; until the coolant temperature reaches normal value, then verify that the ignition advance angle is normal.	Yes	Proceed to next step.
		No	Adjust the ignition advance angle
17	Verify that the compression pressure of engine cylinder is normal.	Yes	Proceed to next step.
		No	Fix the malfunction
18	Verify that the absolute pressure and temperature sensor of air intake manifold has any blockage.	Yes	Repair or replace
		No	Proceed to next step.
19	Verify that the coolant temperature sensor is normal.	Yes	Replace the ECU.
		No	Repair or replace

5) Difficult start-up of cold engine

Item No.	Operation procedure	Inspection results	Follow-up procedure
1	Turn the ignition switch to “ON” position. Inspect with the diagnostic tester verify that there is any malfunction information record.	Yes	Fix the indicated malfunction
		No	Proceed to next step.
2	Inspect with multimeter to see whether the coolant temperature sensor is normal. (Or connect a 1.5KΩ resistance in series with ECU’s pin of 39# and 35# to replace the function of the coolant temperature sensor to start up the engine. If the engine can be started, it indicates that the coolant temperature sensor is abnormal.)	Yes	Proceed to next step.
		No	Replace the sensor
3	Turn the ignition switch to “ON” position and connect the adaptor between ECU and the wiring harness. Verify that the voltages at following ECU pins are normal: 13# is at about 12V of battery voltage; 80# and 61# are at zero.	Yes	Proceed to next step.
		No	Inspect the wiring harness and plug in connector
4	Verify that the air filter is free of any blockage.	Yes	Proceed to next step.
		No	Replace
5	After start up, verify that the air intake manifold pressure is maintained between 35-65 kPa at idle speed.	Yes	Proceed to next step.
		No	Fix the leakage of air intake system.
6	Step on the throttle gently to verify that it is easy to be started up.	Yes	Inspect the throttle valve and idle speed passage.
		No	Proceed to next step.
7	Disconnect the connector of idle speed actuator before the temperature of engine coolant reaches 35°C in order to observe whether the engine speed is decreasing.	Yes	Proceed to next step.
		No	Repair or replace the idle speed actuator
8	Connect the fuel manometer valve (the connecting point will depend on	Yes	Proceed to next step.

	(the connecting point will depend on the types of car models). Ground the 86# pin of the fuel pump relay directly. Connect the ignition switch to operate the fuel pump relay and the fuel pump in order to verify that the fuel pressure is maintained at about 350kPa.	No	Proceed to Step 12
9	Provide a voltage supply of 12V with special connector between the battery and the fuel injector, and verify that the fuel injector functions normally.	Yes	Proceed to Step 11
		No	Proceed to next step.
10	After washing and cleaning the fuel injector, verify again that it can function normally.	Yes	Proceed to next step.
		No	Replace the fuel injector
11	Verify that the fuel is deteriorated or contaminated with water.	Yes	Replace the fuel
		No	Proceed to Step 17.
12	Verify that the fuel pressure is lower than 350kPa.	Yes	Proceed to next step.
		No	Proceed to Step 16.
13	Close the fuel manometer valve. Connect the ignition switch again to re-operate the fuel pump in order to verify that the fuel pressure can be established.	Yes	Proceed to next step.
		No	Proceed to Step 15
14	Open the fuel manometer valve and clamp the fuel return pipe with the fuel tube clamp to stop the fuel return in order to verify that the fuel pressure can be established quickly.	Yes	Replace the fuel pressure regulator.
		No	Repair or replace fuel injector or fuel pipe
15	Verify that the fuel inlet pipe has any leakage or blockage.	Yes	Repair or replace the fuel air inlet pipe
		No	Replace the fuel pump
16	Verify that the fuel return pipe has any leakage or bending.	Yes	Repair or replace the fuel return pipe
		No	Replace the fuel pressure regulator
17	Verify that the pressure of engine cylinder is normal.	Yes	Proceed to next step.
		No	Fix the malfunction
18	Verify that the engine air intake system has any leakage.	Yes	Repair
		No	Proceed to next step.
19	Verify that the absolute pressure and temperature sensor of air intake manifold have any blockages.	Yes	Repair or replace
		No	Replace the ECU.

6) Unstable idle speed at all time

1	Turn the ignition switch to “ON” position. Inspect with the diagnostic tester to see whether there is any malfunction information record.	Yes	Fix the indicated malfunction
		No	Proceed to next step.
2	Verify that the EWD3 idle speed actuator or idle speed actuator with step motor is jammed.	Yes	Repair or replace idle speed actuator
		No	Proceed to next step.
3	Connect the ignition switch and verify that the links between water temperature sensor, idle speed step motor and ECU are properly connected.	Yes	Inspect the wiring harness and plug in connector
		No	Proceed to next step.
4	Run the engine at idle speed and cut off the cylinders one by one in order to observe whether the speed is decreasing or fluctuating.	Yes	Proceed to Step 8
		No	Proceed to next step.
5	Verify that the fuel injector of each cylinder functions normally.	Yes	Proceed to next step.
		No	Inspect the fuel injector and the wiring harness
6	Verify that the resistance of each cylinder high voltage cable is normal.	Yes	Proceed to next step.
		No	Replace
7	Verify that the ignition coil is damaged.	Yes	Replace
		No	Proceed to next step.
8	Verify that the spark plug is normal.	Yes	Proceed to next step.
		No	Replace the spark plug
9	Connect the fuel manometer valve. Short the 30# and 87# pins of the fuel pump relay to operate the fuel pump in order to verify that the fuel pressure is being maintained at about 350kPa.	Yes	Proceed to next step.
		No	Proceed to Step 13.
10	Provide a voltage supply of 12V with special connector between the battery and the fuel injector, and verify that the fuel injector functions normally.	Yes	Proceed to Step 12.
		No	Proceed to next step.
11	After washing and cleaning the fuel injector, verify again that it can function normally.	Yes	Proceed to next step.
		No	Replace the fuel injector
12	Verify that the fuel is deteriorated or contaminated with water.	Yes	Replace the fuel
		No	Proceed to Step 18
13	Verify that the fuel pressure is lower than 350kPa.	Yes	Proceed to next step.
		No	Proceed to Step 17.
14	Close the fuel manometer valve. Connect	Yes	Proceed to next step.

	the ignition switch again to re-operate the fuel pump in order to verify that the fuel pressure can be established.	No	Proceed to Step 16.
15	Open the fuel manometer valve and clamp the fuel return pipe with the fuel tube clamp to stop the fuel return in order to verify that the fuel pressure can be established quickly.	Yes	Replace the fuel pressure regulator
		No	Repair or replace the fuel injector or fuel pipe
16	Verify that the fuel inlet pipe has any leakage or blockage.	Yes	Repair or replace the fuel air inlet pipe
		No	Replace the fuel pump
17	Verify that the fuel return pipe has any leakage or bending.	Yes	Repair or replace the fuel return pipe
		No	Replace the fuel pressure regulator
18	Verify that the sensing holes of the pressure and temperature sensor of air intake manifold have any blockages.	Yes	Clean
		No	Proceed to next step.
19	Run the engine at idle speed. When the coolant temperature reaches the temperature of activating the close- loop control, verify that oxygen sensor functions normally. (Fluctuating within the range of 0-1V)	Yes	Proceed to next step.
		No	Inspect the oxygen sensor and the wiring harness
20	Verify that the engine air intake system has any leakage.	Yes	Fix the leakage
		No	Proceed to next step.
21	Verify that the pressure of engine cylinder is normal.	Yes	Proceed to next step.
		No	Fix the malfunction
22	Run the engine at idle speed until the coolant temperature reaches its normal range in order to verify that the ignition advance angle is normal.	Yes	Replace the ECU.
		No	Inspect other items

7) Unstable idle speed during engine warm-up

1	Turn the ignition switch to “ON” position. Inspect with the diagnostic tester to see whether there is any malfunction information record.	Yes	Fix the indicated malfunction
		No	Proceed to next step.
2	Verify that the air filter is free of any blockage.	Yes	Proceed to next step.
		No	Replace
3	Run the engine at idle speed. Verify that the air intake manifold pressure is maintained between 35-65 kPa during warm-up.	Yes	Proceed to next step.
		No	Fix the leakage of air intake system
4	Shut down the engine. Turn on the ignition switch and connect the adaptor between ECU and the wiring harness. Verify that the voltages at air intake temperature sensor, water temperature sensor, and ECU’s pins of 32# and 33# (used as sensor power supply of 4.5-5V) are normal.	Yes	Proceed to next step.
		No	Service
5	Disconnect the connector of idle speed actuator before ending the engine warm-up and verify that the engine speed is changed.	Yes	Proceed to next step.
		No	Replace the idle speed actuator
6	Verify that the coolant temperature sensor is normal.	Yes	Proceed to next step.
		No	Replace
7	Run the engine at idle speed until the coolant temperature reaches its normal range in order to verify that the ignition advance angle is normal.	Yes	Replace the ECU.
		No	Inspect other items

8) Unstable idle speed or stall with load (A/C and etc.)

1	Turn the ignition switch to “ON” position. Inspect with the diagnostic tester to see whether there is any malfunction information record.	Yes	Fix the indicated malfunction
		No	Proceed to next step.
2	Turn on the A/C switch and connect the adaptor between ECU and the wiring harness. Measure and see whether the ECU’s A/C switch and pressure signal have any signal input.	Yes	Proceed to next step.
		No	Overhaul the A/C circuit.
3	Verify that the pressure of A/C system, the magnetic clutch of compressor and A/C pump are normal.	Yes	Proceed to next step.
		No	Repair or replace.
4	Turn the ignition switch to “ON” position. Verify that the voltages at ECU’s pins of 65#, 64#, 67#, and 66# (output connected to idle actuator) are normal.	Yes	Proceed to next step.
		No	Inspect the control circuit.
5	Remove the step motor to verify that it is jammed or runs unfreely.	Yes	Repair or replace the step motor.
		No	Proceed to next step.
6	Start up the engine and turn on the A/C. Inspect with the diagnostic tester through the step amount of step motor to see whether the idle actuator functions normally. (The normal step amount will be provided otherwise)	Yes	Replace the ECU.
		No	Replace the idle actuator.

9) Unstable idle speed after engine warm-up

1	Turn the ignition switch to "ON" position. Inspect with the diagnostic tester to see whether there is any malfunction information record.	Yes	Fix the indicated malfunction.
		No	Proceed to next step.
2	Turn the ignition switch to "ON" position and connect the adaptor between ECU and the wiring harness. Verify that the voltages at following ECU's pins such as absolute pressure sensor output of air intake manifold, air intake temperature sensor output, coolant temperature sensor output, oxygen sensor output and ECU's output voltage connected to idle actuator's pin are normal.	Yes	Proceed to next step.
		No	Repair or replace the wiring harness and relevant parts.
3	Shut down the engine and verify that the air filter is free of any blockage.	Yes	Proceed to next step.
		No	Replace
4	Verify that the air intake manifold pressure is maintained between 35-65 kPa at idle speed.	Yes	Proceed to next step.
		No	Fix the leakage of air intake system
5	Connect the fuel manometer valve (the connecting points will depend on the types of car models). Short the 30# and 87# pins of the fuel pump relay to operate the fuel pump in order to verify that the fuel pressure is maintained at about 350kPa.	Yes	Proceed to next step.
		No	Proceed to Step 9
6	Provide a voltage supply of 12V with special connector between the battery and the fuel injector, and verify that the fuel injector is functioning normally.	Yes	Proceed to Step 8
		No	Proceed to next step.
7	After washing and cleaning the fuel injector, inspect again to see whether it can function normally.	Yes	Replace
		No	Replace the fuel injector.
8	Verify that the fuel is deteriorated or contaminated with water.	Yes	Replace the fuel.
		No	Proceed to Step 14.
9	Verify that the fuel pressure is lower than 350kPa.	Yes	Proceed to next step.
		No	Proceed to Step 13.
10	Turn off the fuel manometer valve. Connect the ignition switch again to re-operate the fuel pump in order to verify that the fuel pressure can be established.	Yes	Proceed to next step.
		No	Proceed to Step 12.
11	Turn on the fuel manometer valve and clamp the fuel return pipe with the fuel	Yes	Replace the fuel pressure regulator.

	tube clamp to stop the fuel return in order to verify that the fuel pressure can be established quickly.	No	Repair or replace the fuel injector or the fuel pipe.
12	Verify that the fuel inlet pipe has any leakage or blockage.	Yes	Repair or replace the fuel air inlet pipe.
		No	Replace the fuel pump.
13	Verify that the fuel return pipe has any leakage or bending.	Yes	Repair or replace the fuel return pipe.
		No	Replace the fuel pressure regulator.
14	Run the engine at idle speed until the coolant temperature reaches its normal value in order to verify that the ignition advance angle is normal.	Yes	Proceed to next step.
		No	Adjust the ignition advance angle.
15	Disconnect the coolant temperature sensor to verify that the engine is normal.	Yes	Replace the coolant temperature sensor.
		No	Proceed to next step.
16	Verify that the compression pressure of engine cylinder is normal.	Yes	Proceed to next step.
		No	Fix the malfunction.
17	Verify that the resistance of each cylinder high voltage cable is normal.	Yes	Proceed to next step.
		No	Replace
18	Verify that the ignition coil and high voltage cable have any damage parts or cracks.	Yes	Replace
		No	Proceed to next step.
19	Verify that the spark plug is normal.	Yes	Replace the ECU.
		No	Replace the spark plug.

10) A/C system malfunction

1	Verify that there is enough refrigerant and the A/C belt, A/C clutch and pressure switch are in good condition.	Yes	Proceed to next step.
		No	Fix the malfunction.
2	Run the engine at idle speed and turn on the A/C switch. Inspect with the diagnostic tester to see whether there is any malfunction with the A/C thermo-sensitive resistance.	Yes	Fix the indicated malfunction.
		No	Proceed to next step.
3	Turn on the A/C switch and connect the adaptor between ECU and the wiring harness. Measure and see whether the ECU's A/C switch and A/C pressure have any signal input.	Yes	Proceed to next step.
		No	Inspect the wiring harness.
4	If the car is controlled by low electrical level, verify that the A/C still functions when it is turned off.	Yes	Replace the bulb or repair the wiring harness.
		No	Proceed to next step.
5	Verify that there is any low level output from the ground terminal of A/C relay solenoid coil in ECU.	Yes	Repair the A/C relay and the wiring harness.
		No	Replace the ECU.

11) Periodically instability (the memory has to be restored after ECU's power-off)

1	Turn the ignition switch to "ON" position. Inspect with the diagnostic tester to see whether there is any malfunction information record.	Yes	Fix the indicated malfunction.
		No	Proceed to next step.
2	Verify that the air filter is free of any blockage.	Yes	Proceed to next step.
		No	Replace
3	Verify that the air intake pressure is maintained between 35-65 kPa at idle speed.	Yes	Proceed to next step.
		No	Overhaul air intake system and leakage.
4	Run the engine at idle speed and cut off the cylinder one by one in order to verify that the speed is decreased and fluctuated.	Yes	Proceed to Step 7
		No	Proceed to next step.
5	Turn the ignition switch to "ON" position and connect the adaptor between ECU and the wiring harness. Verify that the voltages at following ECU's pins including absolute pressure sensor output of air intake manifold, air intake temperature sensor output, coolant temperature sensor output, oxygen sensor output, electronic grounding, ignition switch pin, and ECU's pins of 65#, 64#, 67#, and 66# (output connected to idle actuator) are normal.	Yes	Proceed to next step.
		No	Repair or replace the wiring harness.
6	Run the engine at idle speed until the coolant temperature reaches its normal value in order to verify that the ignition advance angle is normal.	Yes	Proceed to next step.
		No	Inspect other items.
7	Verify that the sensing holes of air intake manifold pressure sensor and air intake temperature sensor have any blockage.	Yes	Clean
		No	Proceed to next step.
8	Verify that the fuel is deteriorated or contaminated with water.	Yes	Replace the fuel.
		No	Proceed to next step.
9	Apply a voltage supply of 12V directly between the battery and the fuel injector with special connector, and verify that the fuel injector functions normally.	Yes	Proceed to next step.
		No	Overhaul the fuel injector and relevant wiring harness.
10	Verify that the resistance of each cylinder high voltage cable is normal.	Yes	Proceed to next step.
		No	Replace
11	Verify that the ignition coil and high	Yes	Replace

	voltage cable have any damaged parts or cracks.	No	Proceed to next step.
12	Verify that the spark plug is normal.	Yes	Replace the ECU.
		No	Replace the spark plug.

12) Too high idle speed (the memory has to be restored after ECU's power-off)

1	Turn the ignition switch to "ON" position. Inspect with the diagnostic tester to see whether there is any malfunction information record.	Yes	Fix the indicated malfunction.
		No	Proceed to next step.
2	Verify that the fastener connected to the accelerator pedal is jammed or too tight.	Yes	Adjust or replace.
		No	Proceed to next step.
3	Verify that the carbon canister control valve, the fuel pressure regulator, the crankcase forced ventilation vacuum pipe, the brake system vacuum booster hose are assembled well or damaged.	Yes	Repair or replace.
		No	Proceed to next step.
4	Run the engine at idle speed, shift at neutral position, and step on the brake pedal in order to verify that the idle speed is too high.	Yes	Proceed to next step.
		No	Proceed to Step 6
5	Clamp the vacuum booster hose to verify whether the idle speed is normal.	Yes	Repair or replace the vacuum booster.
		No	Proceed to next step.
6	Clamp the crankcase forced ventilation vacuum pipe to verify whether the idle speed is changed to normal.	Yes	Replace the PVC valve
		No	Proceed to next step.
7	Clamp the carbon canister control valve hose to verify whether the idle speed is changed to normal.	Yes	Replace the carbon canister control valve.
		No	Proceed to next step.
8	Verify that the idle actuator is inflexible or jammed.	Yes	Repair or replace.
		No	Proceed to next step.
9	Verify that there is any leakage at other places of air inlet pipe.	Yes	Repair or replace.
		No	Proceed to next step.
10	Verify that the seal ring of fuel injector is in good condition.	Yes	Proceed to next step.
		No	Replace the seal ring.
11	Verify that the absolute pressure sensor of air intake manifold and air intake temperature sensor are in proper conditions.	Yes	Replace the ECU.
		No	Replace the sensor.

13) Malfunction to increase the speed or stall during acceleration

1	Turn the ignition switch to "ON" position. Inspect with the diagnostic tester to see whether there is any malfunction information record.	Yes	Fix the indicated malfunction.
		No	Proceed to next step.
2	Verify that the air filter is free of any blockage.	Yes	Proceed to next step.
		No	Replace
3	Run the engine at idle speed in order to verify that the idle speed is normal.	Yes	Proceed to next step.
		No	Overhaul according to the idle speed malfunction instruction
4	Verify that the air intake pressure is maintained between 35-65 kPa at idle speed.	Yes	Proceed to next step.
		No	Overhaul
5	Run the engine at idle speed until the coolant temperature reaches its normal value in order to verify that the ignition advance angle is normal.	Yes	Proceed to next step.
		No	Adjust the ignition advance angle
6	Connect the fuel manometer valve. Short the 30# and 87# pins of the fuel pump relay to operate the fuel pump in order to verify that the fuel pressure is being maintained at about 350kPa.	Yes	Proceed to next step.
		No	Proceed to Step 10
7	Apply a voltage supply of 12V directly between the battery and the fuel injector with special connector, and verify that the fuel injector functions normally.	Yes	Proceed to Step 9
		No	Proceed to next step.
8	After washing and cleaning the fuel injector, verify again that it can function normally.	Yes	Proceed to next step.
		No	Replace the fuel injector.
9	Verify that the fuel is deteriorated or contaminated with water.	Yes	Replace the fuel.
		No	Proceed to Step 15.
10	Verify that the fuel pressure is lower than 250kPa.	Yes	Proceed to next step.
		No	Proceed to Step 14.
11	Turn off the fuel manometer valve. Connect the ignition switch again to re-operate the fuel pump in order to verify that the fuel pressure can be established.	Yes	Proceed to next step.
		No	Proceed to Step 13.
12	Turn on the fuel manometer valve and clamp the fuel return pipe with the fuel tube clamp to stop the fuel return in order to verify that the fuel pressure can be established quickly.	Yes	Replace the fuel pressure regulator.
		No	Repair or replace the fuel injector or the fuel pipe.

13	Verify that the fuel inlet pipe has any leakage or blockage.	Yes	Repair or replace the fuel air inlet pipe.
		No	Replace the fuel pump.
14	Verify that the fuel return pipe has any leakage or bending.	Yes	Repair or replace the fuel return pipe.
		No	Replace the fuel pressure regulator.
15	Turn the ignition switch to “ON” position and connect the adaptor between ECU and the wiring harness. Verify that the voltages at following pins of ECU including signal output terminal and grounding terminal of the throttle position sensor, and pins of 32# and 33# (used as sensor’s power supply of 4.5-5V) are normal.	Yes	Proceed to next step.
		No	Repair or replace the wiring harness.
16	Verify that the ignition coil, the high voltage cable and the spark plug are normal.	Yes	Replace the ECU.
		No	Repair the relevant parts.

14) Slow respond during acceleration

1	Turn the ignition switch to “ON” position. Verify with diagnostic tester to see whether there is any malfunction information record.	Yes	Fix the indicated malfunction
		No	Proceed to next step.
2	Shut down the engine and verify that the air filter is free of any blockage.	Yes	Proceed to next step.
		No	Replace
3	Run the engine at idle speed in order to verify that the idle speed is normal.	Yes	Proceed to next step.
		No	Overhaul according to the idle speed malfunction instruction
4	Verify that the air inlet pipe pressure is being maintained between 35-65 kPa at idle speed.	Yes	Proceed to next step.
		No	Overhaul
5	Turn the ignition switch to “ON” position and connect the adaptor between ECU and the wiring harness. Verify that the voltages at following pins of ECU including signal output terminal and grounding terminal of throttle position sensor, and pins of 32# and 33# (used as sensor power supply of 4.5-5V) are normal.	Yes	Proceed to next step.
		No	Repair or replace the wiring harness
6	Operate the engine at idle speed and wait until the coolant temperature has reached its normal value in order to verify that the ignition advance angle is normal.	Yes	Proceed to next step.
		No	Inspect other items
7	Connect the fuel manometer valve. Short the 30# and 87# pins of the fuel pump relay to operate the fuel pump in order to verify that the fuel pressure is maintained at about 350kPa.	Yes	Proceed to next step.
		No	Proceed to Step 11.
8	Apply a voltage supply of 12V directly between the battery and the fuel injector with special connector and verify that the fuel injector functions normally.	Yes	Proceed to Step 10.
		No	Proceed to next step.
9	After washing and cleaning the fuel injector, verify again to see whether it can function normally.	Yes	Proceed to next step.
		No	Replace the fuel injector.
10	Verify that the fuel is deteriorated or contaminated with water.	Yes	Replace the fuel.
		No	Proceed to Step 16.
11	Verify that the fuel pressure is lower than 350kPa.	Yes	Proceed to next step.
		No	Proceed to Step 15.

12	Turn off the fuel manometer valve. Connect the ignition switch again to re-operate the fuel pump in order to verify that the fuel pressure can be established.	Yes	Proceed to next step.
		No	Proceed to Step 14
13	Turn on the fuel manometer valve and clamp the fuel return pipe with the fuel tube clamp to stop the fuel return in order to verify that the fuel pressure can be established quickly.	Yes	Replace the pressure regulator.
		No	Repair or replace the fuel injector or the fuel pipe.
14	Verify that the fuel inlet pipe has any leakage or blockage.	Yes	Repair or replace the fuel inlet pipe.
		No	Replace the fuel pump.
15	Verify that the fuel return pipe has any leakage or bending.	Yes	Repair or replace the fuel return pipe.
		No	Replace the fuel pressure regulator.
16	Verify that the exhaust system and the 3-way catalytic converter have any blockages.	Yes	Replace or clean.
		No	Replace the ECU.

15) Poor and weak performance during acceleration

1	Verify that there are any malfunctions such as slipping of clutch, low pressure of tires, delay in braking, and wrong size of tires or inaccurate four-wheel alignment.	Yes	Repair
		No	Proceed to next step.
2	Verify that the throttle can be fully opened.	Yes	Proceed to next step.
		No	Replace or repair the throttle
3	Turn the ignition switch to "ON" position. Inspect with the diagnostic tester to see whether there is any malfunction information record.	Yes	Fix the indicated malfunction
		No	Proceed to next step.
4	Run the engine at idle speed until the coolant temperature reaches its normal range in order to verify that the ignition advance angle is normal.	Yes	Proceed to next step.
		No	Inspect other items.
5	Turn the ignition switch to "ON" position and connect the adaptor between ECU and the wiring harness. Verify that the voltages at following pins of ECU including absolute pressure sensor of air intake manifold, throttle valve position sensor, air intake temperature sensor, coolant temperature sensor, oxygen grounding terminal and signal output terminal, sensor signal grounding terminal and pins of 32# and 33# (used as sensor power supply of 4.5-5V) are normal.	Yes	Proceed to next step.
		No	Repair or replace the wiring harness.
6	Verify that the air intake pressure is being maintained between 35-65 kPa at idle speed.	Yes	Proceed to next step.
		No	Overhaul
7	Connect the fuel manometer valve. Short the 30# and 87# pins of the fuel pump relay to operate the fuel pump in order to verify that the fuel pressure is being maintained at about 350kPa.	Yes	Proceed to next step.
		No	Proceed to Step 11.
8	Apply a voltage supply of 12V directly between the battery and the fuel injector with special connector and verify that the fuel injector functions normally.	Yes	Proceed to Step 10.
		No	Proceed to next step.
9	After washing and cleaning the fuel injector, verify again that it can function normally.	Yes	Proceed to next step.
		No	Replace the fuel injector.
10	Verify that the fuel is deteriorated or	Yes	Replace the fuel.

	contaminated with water.	No	Proceed to Step 16.
11	Verify that the fuel pressure is lower than 350kPa.	Yes	Proceed to next step.
		No	Proceed to Step 15.
12	Turn off the fuel manometer valve. Connect the ignition switch again to re-operate the fuel pump in order to verify that the fuel pressure can be established.	Yes	Proceed to next step.
		No	Proceed to Step 14.
13	Turn on the fuel manometer valve and clamp the fuel return pipe with the fuel tube clamp to stop the fuel return in order to verify and see whether the fuel pressure can be established quickly.	Yes	Replace the pressure regulator.
		No	Repair or replace the fuel injector or the fuel pipe.
14	Verify that the fuel inlet pipe has any leakage or blockage.	Yes	Repair or replace the fuel inlet pipe
		No	Replace the fuel pump.
15	Verify that the fuel return pipe has any leakage or bending.	Yes	Repair or replace the fuel return pipe.
		No	Replace the fuel pressure regulator.
16	Verify that the data of the absolute pressure sensor of air intake manifold and air intake temperature sensor are normal.	Yes	Proceed to next step.
		No	Replace the sensor.
17	Verify that the ignition coil, the high voltage cable and the spark plug are normal.	Yes	Proceed to next step.
		No	Replace or adjust
18	Verify that it is caused by the A/C system.	Yes	Inspect the A/C system
		No	Replace the ECU.

SAFETY PRECAUTIONS OF SYSTEM MAINTENANCE

SAFETY PRECAUTIONS IN DIAGNOSIS AND MAINTENANCE OF THE GASOLINE INJECTION ELECTRONIC CONTROL SYSTEM

(1) Removal/installation requirements of controller

The battery negative grid must be disconnected first, followed by the removal of controller prior to carrying out electric welding or baking finish;

In removing/installing the controller, the ignition switch must be turned to “OFF” position to avoid being damaged;

The power supply wire should not be removed from the battery while the engine is running or the electrical system is in operation;

Don't start the engine with high current of charger;

Pay attention to keep the ambient temperature around controller less than 80°C.

(2) Cleanliness requirements: following rules shall be complied strictly before operating the fuel supply system and fuel injector system:

All the dismantled parts must be placed in clean environment and covered properly. It is not allowed to use the fiber-sloughing cloth.

(3) All the wiring harness and the same for diagnostic tester can only be disconnected or connected after the ignition switch has been turned off;

Ensure the wiring connection is correct before carrying out the voltage or grounding measurement for the electronic control system.

Remove the power supply wire from battery or disconnect the wiring harness controller connectors will cause the loss of diagnostic information and memory.

(4) Notes for maintaining the fuel supply system:

Attention must be paid to the followings when removing and installing the fuel pump on a fully or semi-fully filled fuel tank:

A device that can fully absorb the potential leaked fuel should be available near the fuel tank opening before carrying out the operation;

Avoid the skin come into direct contact with fuel;

Thoroughly clean the place and around it before loosening the connecting parts;

Put rags around the connecting parts in order to prevent the fuel from spraying via the loosened part;

The disassembled parts that are not intended to be repaired immediately should be covered or closed carefully;

The spare parts should be taken out from its packing only before the assembly. Any part without proper packing is not allowed to be used;

Pay attention not to damage the O ring while assembling the fuel injector. A small amount of lubricating oil should be applied on the O ring for assembly convenient.

After the system has been opened up, as far as possible not to use compression air and move the car around.

SAFETY MEASURES

Attention should be paid to the followings so as to avoid the injury of personnel and damage of the fuel injectors and the ignition device:

- (1) If the engine is running or at the start up speed, then it is not allowed to contact or disconnect the ignition wiring harness;
- (2) If the engine is driven by the starting motor instead of starting by itself, such as in the case of inspecting the compression pressure, then the wiring harness connectors should be disconnected from the Hall Sensor and crankshaft position sensor.