

Preface

Thanks for your using JAC trucks!

Before your using JAC trucks, please read this operating specification carefully and operate the trucks according to the specification to bring JAC trucks' excellent performance into full play and keep the trucks in a good running state in a long time!

JAC trucks are developed and produced jointly by Anhui Province Automobile Research Institute and Anhui Jianghuai Automobile Co., LTD. As well as the road conditions are taken to fully condition, the domestic and overseas modern design and producing technique of body and chassis are absorbed and adopted to let JAC trucks bear good smoothness and possibility, safe and reliable brake, easy and light control, convenient usage and maintenance.

As a result of continuous progress in the technique, JAC trucks are also innovated and improved. All the diagrams and data in the specification are based on the latest material when compiling. We would not inform you after making some modification on it. Please forgive us for it.

For the reason of hastiness, there may be some defect in it, and we are honored to receive your suggestion and advice.

The technology consultation telephone number: 0551-2296374

The service consultation telephone number: 0551-2296361

Anhui Jianghuai Automobile Co.

ANHUI JIANGHUAI AUTOMOBILE CO., LTD.

May. 2008

Notice! Please read these following items carefully before using JAC trucks!

I .As regards JAC trucks, please pay attention to these following items:

1.It is forbidden to make refitting and adding equipment without our permission, especially on the electric appliance, brake, steering and so on that will affect the safety system of the products.

JAC will not take upon herself the loss owing to your refitting and adding equipment without our permission!

2.when using JAC products, please make timely maintenance and service according to the service manual to bring the good performance of your loving truck into full play.

3.Please be sure to go to special repair shop of JAC for service if finding problems in using; please use genuine parts of JAC if needing to change parts. JAC will not take upon herself the loss owing to your not using genuine parts.

4.Any consumer that uses JAC complete vehicle or chassis is forbidden to change its product identification and name-plate, or the consumer will be responsible for it.

II .As regards the special purpose chassis of JAC, please pay attention to the following items:

1. It is forbidden to lengthen or widen the frame of JAC without JAC's permission, or you will take upon yourself the loss for it.

2.As regards the refitting on JAC special purpose chassis, all the refitting companies should not make the refitted models be contradict with the traffic regulations and the relevant rules of the nation, or JAC will not be responsible for it.

Contents

I \ Use of vehicle	1
II \ Engine	21
III \ Chassis	29
IV \ Electrical equipment	55
V \ Vehicle service and maintenance	61
VI \ Trouble shooting	65
VII \ Automotive model table of trucks	85
VIII \ Appendix	89
Main files alone with the vehicle	94

I . Use of vehicle

- (I). Use of instruments and apparatuses in the cab
- (II). Use of components in the cab
- (III). Start and running of vehicle

(I). Use of instruments and apparatuses in the cab

1. Integrated switch and instrument cluster

Integrated switch (figure below) which is composed of steering shaft lock seat, ignition start lock and combination switch lies underneath the steering wheel.

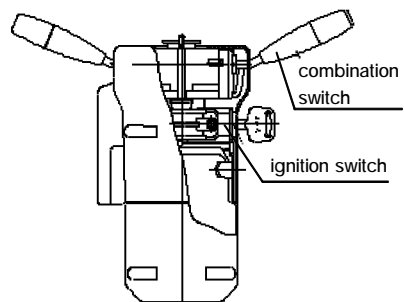

schematic diagram of integrated switch

1) Ignition switch

Ignition switch is on the right side of integrated switch. It has four functions: LOCK, ACC, ON, START. When the key is on the 'LOCK' position, the ignition switch has been connected to the power source and the lockup of steering gear has been disengaged. Turn the key to 'ACC' position clockwise, the circuit of accessories like radio and tape player can be connected. Turn to the 'ON' position, and the instrument circuit is connected. If keep on turning until to the 'START' position, the engine can be started. You should unlash the handle of the key immediately after the engine started. And the key can return to the 'ON' position by the ac-

tion of spring. The schematic diagram of ignition switch is as follows.

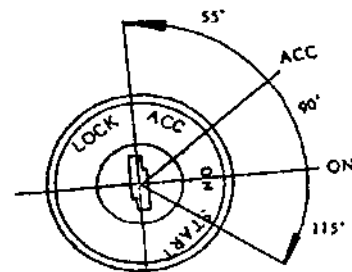



schematic diagram of ignition switch
2) Combination switch (left control handle)



left control handle

Combination switch is under the control of the multifunction handle, which lies in the lower left and inferior place of the steering wheel. It can control small light, headlight, headlight dimmer and turning to the left or the right by two different movement modes. The symbol and function of the combination switch is as follows:

- ① The OFF symbol indicates that small light and headlight do not light. (But at this time the high beam can light if you put up the handle.)
- ② The  symbol is the indication of small light. Turn the control handle clockwise by 30°, and the front, rear small lights and the instrument light can light.
- ③ The  symbol is the indica-

tion of headlight. Keep on the turning of the left control handle clockwise by 30°, the front headlight, the rear small light and the instrument light can light.

- ④ The  symbol is the indication of steering. Forward and backward motion of the control handle can operate the left and right turning lamp and the turn light indicator in the instrument panel. Push the control handle forward in the horizontal direction, the right turning lamp lights and there has the indication of turning right in the instrument panel. On the other hand, pull the control handle backward, the left turning lamp lights and there has the indication of turning left in the instrument panel. If



the control handle is in the middle position, then there has no indication of turning.

- ⑤ Dimmer of headlight: Lift the left control handle upwards gently and do the 'uplift-looseness' motion, it can control the dimmer function of the headlight. Uplift the handle once, high beam headlamp lights; loose the handle, it goes out. Repeating the above action can control the work status of the high beam headlamp to obtain the purpose of dimmer function when overtaking or passing in night.

3)Combination switch (right control handle)



right control handle

- ① The  symbol is indication of the scrubber. When the washer control button on the top of the control handle pressed, the cleaning mixture (using antifreeze fluid in winter) in the window washer which lies in the right doorframe and underneath instrument panel can be spouted to the windshield glass through the spout under the window.
- ② The  symbol is indication of

the wiper. Turning the control handle clockwise in the horizontal direction can control the wiper. Turn the control handle clockwise by 12° to the 'LO' position, then the wiper works with low speed. Keep the turning clockwise for another 12°, the wiper can work with high speed. When the control handle is on the original position, it can be disconnected or returned automatically.

③ The  symbol is indication of exhaust throttle assistant braking. Lift the right control handle upwards and do the 'uplift-looseness' motion. Uplift the handle, then the switch can be connected and the indicator lamp in the instrument panel lights. This shows that exhaust throttle assistant

braking works. If the accelerator pedal or the clutch pedal was stepped, the exhaust assistant braking should cancelled automatically and the indicator lamp in the instrument panel went out.

4) Other electric appliance switch (seen in the left and below figure) Other electric appliance switches mainly include horn button, danger warning switch, fog lamp switch, courtesy lamp switch and ceiling light switch.

- ① The horn button is in the center of steering wheel, when the button is depressed it can hoot.
- ② The  symbol (the right and below figure) is indication of danger warning switch. If the button is de-

pressed, the front、rear、left、right turning lamp flash at the same time and send out emergency signal for alarm indication. Press the button again, reset signal of the switch disconnected.

③ The  symbol (the right and below figure) is indication of the fog lamp. If pressed, the fog lamp lights. Press again, the switch resets.

④ Ceiling light signal indicates that the door of the vehicle is shut closely or not. When there have one door opened or did not shut closely, the ceiling lamp lights to remind driver.



other electric appliance switch



danger alarm and fog lamp switch

5) instrument cluster

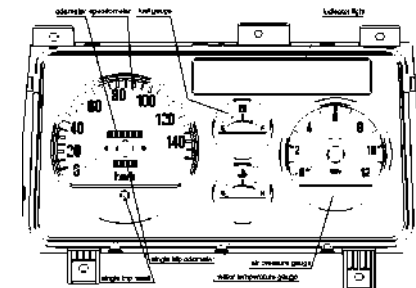

instrument cluster(air brake)

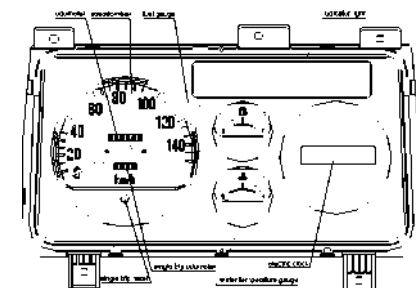

instrument cluster(hydraulic brake)

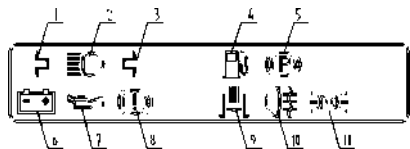

- 1, turn left 2, high beam 3, turn right
4, fuel alarm 5, parking brake
6, charging 7, oil pressure alarm
8, braking fault 9, exhaust assistant
brake 10, fog lamp 11, small light
indicators

Indicators (figure in the above page):

- ① Turn indicator lamp (↔): when the turning control handle is on the left (right) turning position, left (right) turning indicator lamp flashes. If the warning switch is pressed, the left and right turning indicator lamps flash at the same time.
② High beam indicator lamp (≡D): indicates that the headlamp is in the

status of high beam or not. When the headlamp is on the high beam status, the indicator lamp lights.

③ Fuel warning lamp (⛽): fuel level alarm, when fuel is in shortage, fuel alarm lamp lights.

④ Parking brake indicator lamp (P): when pull up the parking brake handle, the indicator lamp lights.

⑤ Exhaust assistant brake indicator lamp (⚡): when exhaust assistant braking operates, the indicator lamp lights. When exhaust assistant brake is disconnected, the indicator lamp goes out.

⑥ Oil pressure indicator lamp (⚡): indicates low - pressure warning of engine oil pressure. When oil pressure is lower than 0.08-0.1Mpa, the

oil pressure indicator lamp lights. When oil pressure is higher than the value, the oil pressure indicator lamp goes out.

⑦ Braking fault indicator lamp (!): when braking fluid is not enough, the indicator lamp lights.

⑧ Exhaust assistant brake indicator lamp (⚡): when exhaust assistant braking operates, the indicator lamp lights. When exhaust assistant brake is disconnected, the indicator lamp goes out.

⑨ Fog lamp indicator lamp (☁): when braking fluid is not enough, the indicator lamp lights.

⑩ Small light indicator lamp (⚡): When they work, the indicator lamp lights.

(II). Use of components in the cab

Cab

Brief description of the structure

The driver cab is forward control cab with full metal enclosed construction. Window glass adopts panoramic camber windshield. In order to improve the comfort, side panel with larger upside width and raised-roof cab have been adopted. Therefore the interior space of the cab can be more commodious and comfortable. Effective measures have taken in reduce noise, heat insulation, sound insulation and sealing. For instances, the section of roof forehead is enclosed and strengthening rib is equipped on the roof. There have

three asbestos heat insulating matress on the upside of the engine. Sealing of the door is double skin construction. At the aspect of safety, softening has done to the main parts, which can appear knocking easily with passengers.

The air condition system (choose to pack)

1. Brief introduction

The automobile air-conditioner and the automobile instrument panel is an integral body which have cold air and warm air machine. It has many useful functions, or example, to making cold air, warm air and to removing frost. The air-conditioner system has four high and low steps,

so the customer can choose what you like, for example, can choose the same way to sending wind.



2. Operation

2.1 To operating the engine

2.2 To press the switch for the air-conditioner, then operating the air volume. The switch has four grades, from left to right, so the air volume of air-conditioner will be more and more strong.

2.3 To operating air -conditioner switches 5,then the compressor begins to work at this time .The whole system will be colder.

2.4 Using the cold wind , please put the temperature adjusting handle 3 to the COOL position .Using the warm wind ,you should put in the HOT position .To changing the wind -position ,choose the handle 2 can make the cold (warm) breeze never lead with direction .If you want to using the warm wind ,you should be close switch of the air condition.

2.5 To turning the natural wind conversion , then pressing the handle 1can make the natural wind from outside of the car.

3.Caution

3.1 You should be avoid the handle in the most cold position when using the air -conditioner in order to prevent evaporate the machine from frost.

3.2 Do not park the cars under the sun .

3.3 To using air -conditioners, you should be close windows and doors of the cab.

3.4 To cleaning the condenser , you should be wash with the compressed air or cold water ,do not wash it strictly with the hot water or steam.

3.5 The air -conditioner does not use in winter , however ,you should be revolve compressor once a week about five minutes .In order to main-

tain the air -conditioner for normal worked.

3.6 If you want to use the air heater , the temperature degree of engine should reach to 70 °Cs above .At 0°C s the automobile should not park in the cool environment, it should be use antifreeze fluid, in order to preventing frost radiator and air heater.

3.7 If you do not know the preventions about the air -conditioner , do not switch it , the in order to prevent results in trouble.

The top of cab's ventilating device which has two ways for it .One is exterior air with indoor ,another one is house airiness .

i. Leading exterior air

(1) Clockwise the rotary -knob on the

top of cab that you definite the top cab is closed.

(2) Turn on the switch to "IN" then turn on the rotary knob to "OPEN" .

ii. Indoor airiness

(1) Clockwise the rotary knob to closing the ventilator louver.

(2) Turn to the switch to "out "which is the exhaust gear position.



Door

1) The cab door, which have three -

step opening, can improve the convenience for passengers getting on or off. The opening angle of the door can be 30o、57o and 90o. The former two angles are partially open and the last angle is full open. On all the three positions, the door can be in stable condition.



outside door handle



lock button

2) Outside door handle

Pull out the outside door handle, and then the door can be opened. Insert the starting switch key into the door lock and turn, the door can be locked.

3) The door can be locked outside without the key. First press down the lock button (figure in the above page) at the inner side of the door to the fixed position, then pull the outside door handle outwards and at the same time close the door.

4) Pull out the inside door handle, and the door can be opened. After closing the door, the door can be locked if the lock button is pressed down.

Cab seat

Cab seat can be classified as driver seat, assistant driver seat and rear row seat. Driver back seat adopts up-right seat. The angle of backrest and the fore-and-aft position of seat can be adjusted. The maximum adjustable angle of the backrest is 56°. The maximum adjustable distance of the seat is 160 mm. The seat adjust system is shown in the right figure.

When vehicle is in the progress of maintenance, please clean the track assembly of the driver seat, recoat the lithium base grease, and tighten all joint nuts again. If found that the cab track slide seat has shaking or block because of distortion, it should be repaired or replaced with components.



Cab tilt lock mechanism

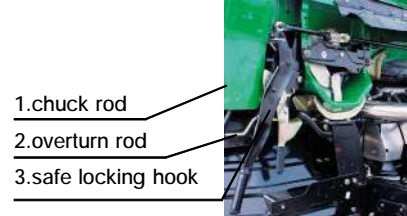

schematic diagram of cab tilt locking device



notice

Brief of the structure

The cab has turnover functions, also has turnover and lock up organization. The turnover was composed of torsion bar, supporting axle,

cab's rear bracket and so on. The cab to turnover is used by torsion power. Lock up system is composed of right/left lock unit, turnover lock unit, short pull rod, long pull rod, rear bracket of cab and so on. All of this is to lock the cab too tightly. (as picture)

Please read the tilting notes on the left door of the cab and on the upper flange of the wheel seriously before tilting the cab. The notes are shown in the upper figure

Use and maintenance

In order to tilting the cab reliably and running the vehicle safely, please pay attention to following contents.

(1) Cab tilting method and relative attentive notices.



support rod assembly

① When the vehicle is stopped on the horizontal road, you should make sure that there has enough space around the cab before tilting. Or else, the cab may be damaged while tilting.

② Pull up the parking brake; push the shifting lever into the neutral position to avoid the self-sliding of the vehicle.

③ The cab door must be fastened up. You should take all goods on the instrument panel, seat and floor away to avoid the damage of the door and the front windshield.

④ First disengaged the locking function of the cab locking mechanism when tilting the cab.

⑤ After the locking function disengaged, hold the tilting rod with hand and pull up the safety lock hook at the same time to avoid the sudden uplift of the cab.

⑥ Raise the cab slowly until it is tilted to the maximum position, then

lock it reliably with lock arm on the rear bracket. It is shown in the right figure.

⑦ When lowering the cab down, first hold the tilting rod and disengage the locking function of lock arm on the rear bracket, then lower the cab down slowly. After the safety lock locked, fasten the locking mechanism.

(2) Inspection and maintenance

① Check periodically the rubber pad assemblies which are used to strengthen the front, rear support, if find damaged, it should be replaced instantly.

② Check periodically the locking situation of the locking mechanism, if invalidation of locking function found,

it should be repaired or replaced immediately.

③ If felt arduous when tilting up the cab or heavy when dropping down the cab, the torsion rod is invalid. Replace the torsion rod.

④ When repairing the chassis, before removing of the cab, disengage the force of the torsion rod and operate with following steps.

a. Disengage the locking state, and tilt up the cab to the utmost position.

b. Remove the shaft pin connected the rear support rod and the base board support of the cab.

c. Push the cab forwards for some angle until the bolt on the torsion rod arm can be loosened.

d. After the bolt removed, the torsion

rod cannot work. Now the cab can be removed (The torsion rod can not be pulled out).

Note: The above-mentioned work must be done by three persons at least because two or three persons cannot push the cab forward after the force of the torsion rod is disengaged.

⑤ Before reverting the cab to the original position, return the force of the torsion rod and operate with following steps:

a. Put the tooth part of the spline which is cut at the bottom on one end of the torsion rod in alignment with '1' position on the support axle tube and the spline tube, and insert the torsion rod into the support axle

tube (for the rod which is pulled out).

b. After mount the cab with support axle tube and the left, right bracket together to the frame, put the '1' of hub splines on the torsion rod in alignment with the spline tooth which is cut at the bottom on the other end of the torsion rod, cover the hub splines on the torsion rod and insert the spline axle tube into the right bracket in the cab.

c. Tilt the cab forwards until the bolt hole on the torsion rod arm aimed at the screwed hole on the right bracket in the cab, screw the bolt and tighten it.

d. Put the cab down slowly, and check whether the cab is on the

state of suspending at the horizontal direction after dropped down. If normally, then lock the cab.

⑥ If find invalidation of the torsion rod, when replacing, operates according to ④ ⑤.

(III). Starting and running of the vehicle

1. Starting of the vehicle

1) Starting of the engine

When starting the engine, put the shift bar on the neutral position, turn on the ignition switch, check horns, instruments on the instrument panel, turning lamps, braking lamps, the angle and position of the rear view mirror.

① Routine start

Turn the key to the START position (shown in the right figure), the engine can start. After starting, loosen the accelerator pedal immediately and keep the engine working in low speed. Depressing the accelerator pedal violently is forbidden.

② Start in winter

When the weather is very cold, the start of diesel engine can take following measures:

a. Cooling water use hot water, and unclose the drain switch when adding hot water. When the hot water flowed out and the engine body became warmer, close the drain switch.



starting switch

b. Heat up the oil up to 80°C~90°C, and then add it into the oil pan.

After starting the engine, check the operating state of the engine and instruments at different rotating speed. Especially check the oil pressure. Check if there have leakage of water, oil and gas, check whether the

oil level is normal and the engine have abnormal noise. Check whether the color of exhaust is normal.

③ After starting the engine, do not depress the accelerator pedal violently, loosen the accelerator pedal to keep the engine operating on idle for some time. After the temperature of engine rises and the engine operates stably, uplift the clutch pedal slowly.

④ Generally after the temperature of engine become more than 60°C and the operating (sound) of the engine components, the reading of instruments are normal, the vehicle can run. Do not run the vehicle in low temperature to avoid intense wear of the engine.

2) Starting and shifting of the vehicle

After engine operates normally, depress the clutch pedal, shift into low gear, loosen the parking brake, and press the horn once. Making sure that the vehicle can be operated safely, loosen the clutch pedal slowly and depress the accelerator pedal properly at the same time to start the vehicle. After starting the vehicle, the foot should get away from the clutch pedal. Do not keep the foot on the pedal to avoid the burning out of the clutch friction disc.

Note: Do not let the vehicle running in first or second gear for long time to prevent from increasing the wear and the fuel consumption. Loosen the clutch pedal rapidly or depress the accelerator pedal insufficiently,

the engine can stop.

When running the vehicle, shift the gear according to the change of road and landform. If find that the engine power is in abundance and the rotating speed rises, it illustrates that the primary gear is not appropriate, the vehicle should be shifted to the next fast gear in time. After shifting, if not finding shortage of power and chattering of transmission, the shifting operation can be considered right. If find shortage of power or the vehicle speed decreases, the vehicle should be shifted to a low gear. If the vehicle runs normally after shifting, the shifting into low gear is right.

for safety, when swerve, passing bridge and meeting, the vehicle can

run in moderate speed. On better running condition, the vehicle can operate in fast gear, and at this time the vehicle speed is high, the fuel consumption is low, the economy of fuel is good.

When shifting, do not just see the shifting lever. You should watch forwards, hold the steering wheel steadily with your left hand, let the center of the palm of your right hand stuck to the top part of the shifting lever and push or pull it to the needed position with the force of your right wrist.

2. Running, swerve, turnarounds, backing and braking of the vehicle

1) Running

Keep enough distance to the foregoing vehicle when running on flat road. Select vehicle speed according to the vehicle model, mission and concrete condition of road, generally select the speed of 50~70 km/h.

Let the vehicle running in the first or second gear when starting, upgrading under heavy load and running on bumpy road or on the road having obstacles. But the vehicle can not run in the first or second gear too long in normally running. When upgrading with heavy load, shift the shifting lever into low gear to avoid

overloading of the engine.

When running, do not increase or decrease the vehicle speed abruptly and not shake the steering wheel without reason, listen whether there is abnormal noise or not, check the reading and indicator lamp of all instruments for normalization. If find abnormal noise or abnormal events, stop the vehicle immediately and check it, take necessary adjustment and repair.

When downgrading, do not stall the engine. When downgrading steep ramp, shift the shifting lever into low gear and take braking operation at intervals to avoid the over fast of the vehicle speed.

When running across shallow river or

lollily, prevent the water from entering into air intake lines of the engine, rear axles and transmission case. Check rear axles and transmission case for entering water after paddling. If find water, drain it and add gear oil with specified quantity. After paddling, the vehicle can not run in high speed. You should depress the braking pedal every now and then to resume the braking performance as soon as possible.

When running on the ice or snow road, run with steady speed. Do not take emergency braking and not turn the steering wheel fiercely to avoid skidding danger. Keep long safety distance from the foregoing vehicle.

When running in heavy rain, drive the

vehicle more carefully to avoid decreasing the braking performance of the brake because of moist. Do not take emergency braking operation to avoid the danger of skidding.

2) Swerve

Swerve of the vehicle produces centrifugal force which can be bigger when the vehicle speed becomes higher. The force can bring turning over in the transverse direction in serious condition. Therefore, at the 50~100 meters position before turning the vehicle, you should ring the horn, turn on the turning lamp and reduce the vehicle speed. When running on the freezing and muddy road or in the weather of heavy rain, fog, wind, sand, reduce the vehicle

speed to less than 10 km/h, swerve the vehicle slowly alongside the right side of the road. When swerving, turn the steering wheel uniformly according to the situation of road, the swerving track should be transited smoothly, the turning motion should not be too great or too small. Do not turn or return the steering wheel suddenly. Try your best to avoid taking braking operation while turning the steering wheel, especially emergency braking.

When steering, if found skidding of front wheels, put up the accelerator pedal and turn the steering wheel in the contrary direction; if found skidding of rear wheels, turn the steering wheel properly along the skidding

direction, and after the skidding stops, correct the running direction.

3) Turning around

When turning around for 180°, select the square, large-scale crossing or flat broad road which have little traffic flux and turn around the vehicle at a time along the running direction. At the 50~100 meters position in front of the turning spot, reduce the vehicle speed, shift into low gear and send out the turning around signal.

When turning around with running forwards and backwards, first send out the turning around signal, reduce the vehicle speed and run towards the right side of road. When approaching the preset spot for turning around, observe the situation of road,

turn the steering wheel to the left extreme position rapidly and let the vehicle running to the left side of road slowly. When approaching the roadside, return the steering wheel rapidly. After observing the situation behind the vehicle, start and turn around the vehicle, turn the steering wheel to the right extreme position at the same time. When approaching the roadside, return the steering wheel rapidly and stop the vehicle. If the turning around operation can not be done once time, repeat the above operations.

4) Backing

The operation of shifting into reverse gear or shifting from reverse gear to onward gear can be done after the

vehicle is stopped completely. After shifting into the reverse gear, the back -up lamp lights. The vehicle speed must be less than 5 km/h when backing. If the driver can not discern the situation behind the vehicle because the vehicle is loading or other reasons, the backing operation must be commanded by one person who is outside the vehicle. Do not back the vehicle blindly.

5) Parking of the vehicle and stop of the engine

When preparing to park the vehicle, the vehicle speed reduces or the vehicle slides out of gear and indicates with turning lamp. After the vehicle parked, pull up the parking brake lever. If the vehicle must be parked

on the road for some reason, park the vehicle near the roadside and not park the vehicle on the running lane. Under the exceptional condition like breaking down in the middle of road, two caution plates should be placed on the position of 200 meters in front of and behind of the vehicle.

Avoid parking on the ramp. If the vehicle must be parked on the ramp, pull up the parking brake lever to the extreme position, shift into low gear and block the vehicle with triangular chocks or stones to prevent it from sliding. Note: Make sure that the parking brake can work reliably when parking on the ramp, at the same time turn on the emergency warning signal indicator lamp.

After parking, especially after the engine operates with heavy load, do not stall the engine immediately, but keep the engine operating in low speed for several minutes. After the temperature of water decreases less than 70°C, then stop the engine.

When parking midway in winter, take the heat preservation and antifreezing measures for the engine. Prevent the oil tank from insolation in summer.

After the vehicle runs a day, routine service and inspection should be done on the entire vehicle.

II .Engine

(I). Inlet air \ exhaust systems

(II). Cooling system

(III). Accelerating transmission system

(IV). Fuel supply system

Notice: The details of the engine structure, assembling, adjustment, using and maintenance can be consulted in the operating specification of relevant engines.

The position of the engine card

Cause: The card of engine is on the top cylinder head or on the side of engine. It writes the model number of engine, sequence number, declared power, declared speed and the factory date. Pay attention to find it in order to using it clearly and convenience. (as picture)

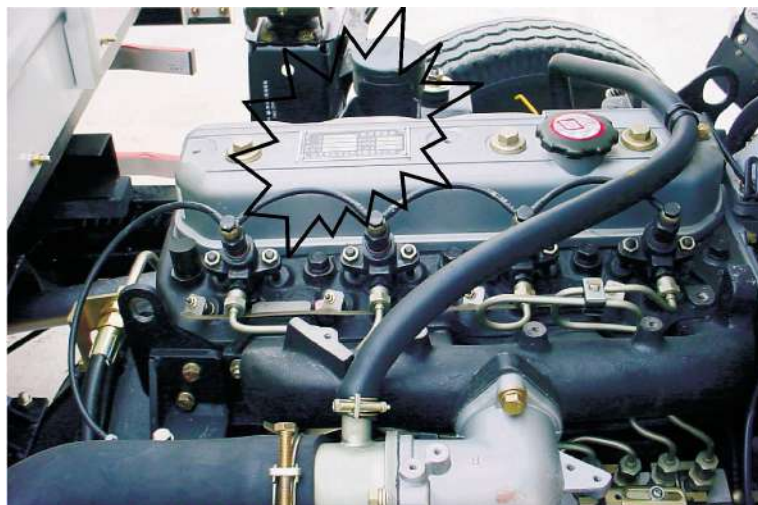

(I). Inlet air, exhaust systems

1. Brief description of the structure

Inlet system includes air inlet pipe assembly, air filter assembly, intake manifold. Exhaust system includes exhaust pipe, muffler and exhaust tailpipe

Use and maintenance:

1) The service life of the engine has great relationship to the workmanship of the air filter. Absolutely forbid that the engine works without air filter or on the condition that the air filter is disabled. Taking the intake opening of air filter as the original intake opening is forbidden.

2) For every 1000km running, check the inlet and exhaust manifold for the following:

a. Check nuts for looseness, when tightening the nut on the inlet and exhaust manifold, the torsion force should be equable, or else the air leakage can occur.

b. Check the inlet and exhaust manifold for crack and hole, check the gasket for damage and erosion, if found, replace it with a new one.

Air filter

The function of air filter is to filter out the dust and the sand in the air entered into the engine.

Air filter is cyclone dust gathering air cleaner with paper filter element. After external air enters into the air filter

through the air inlet pipe, larger dust particle can be separated from the air by the function of cyclone vane, then can be thrown into the dust gathering plate, the separated air keep on moving and enter into the cylinder by the filtering function of the paper element.

For every 1000km running, check and maintain the air filter. When running in the condition of excessive dust, the running mileage interval for inspection and maintenance should be shortened suitably.

Cleaning of the air filter:

1) Remove the dish-shaped nut from the end cover. Take away the end cover, remove the inner nut and take off the filter element assembly.

2) Clean the cover cap and the inner part of the housing with dry and clean cloth. When cleaning, do not let the moisture enter into the air filter.

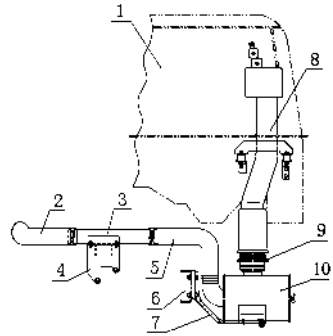

- 1, cab
 - 2, vent hose (1) of the air filter
 - 3, intermediate connecting pipe
 - 4, connection board
 - 5, vent hose of the air filter
 - 6, right longitudinal member of the frame
 - 7, air filter bracket
 - 8, intake pipeline of the air filter
 - 9, connecting hose
 - 10, air filter
- schematic diagram of air filter

3) To cleaning dust unloading valve in order to usage well .

4) Tight and close the rubber of connected brake .

5) Clean the air filter element: clear away the dry dirt or dust with compressed air gun (air pressure should be less than 690kpa), blow from the inner side of filter element towards outside. Do not clear away the dirt or the dust with beating or knocking.

(II). Cooling system

1. Brief description of the structure

Cooling system is closed water cooling pressure cycle type. It is composed of radiator, cooling fluid, thermostat, fan, bulge radiator and water inlet and outlet pipes of radiator.

The concrete structure and type of the cooling system components can be consulted in detail in the operating specification of relevant engines.

2. Using and maintenance of cooling system

1) Recommend using long effective antifreeze preservative liquid for cooling fluid. In the north, it can avoid the damage of engine because of the freezing of cooling fluid in winter; in the south, it can increase the boiling point of cooling fluid in summer to avoid the damage of engine overheating because of air resistance in high temperature.

2) Before dispatch the vehicle every time, check the liquid level in the radiator and in the bulge radiator, if

found it is not enough, add liquid to the specified height.

3) Drainage of cooling system. In cold region and in winter, without using antifreeze preservative liquid, if long time parking or receiving the vehicle everyday, the cooling system must be drained. And you should open the water filler cap of the radiator to avoid the incomplete drainage of cooling water.

4) After engine operating for long time, furring can produce in the cooling water and it should be cleaned in time. Clean it with following method: mix 700 ~800 gram caustic soda and 150 gram kerosene, add the mixture liquid into the cooling water, run in medium

speed for 5 ~10 minutes, then after stopping for 10~12 hours, restart the engine and run for 10~15 minutes. Then drain the aqueous solution and clean the cooling system with cleaned water.

3. Advertent proceedings in using long effective antifreeze preservative liquid

1) Choose suitable antifreeze liquid according to the minimum temperature of the region, if the minimum temperature of the region is -25°C , antifreeze liquid whose solidifying point is -30°C should be chosen.

2) When compensating antifreeze preservative liquid, choose the same model to avoid deposition.

3) If find deterioration of antifreeze

preservative liquid, replace it entirely at once. The color of antifreeze liquid is green or blue, if having deteriorated, the color should be dull red because of impurity infiltration.

To adjusting the degree of tension of the fan belt

1. The disadvantage of engine is tighten or lax the fan belt. Before use it please read the operating specification.

2. The way of adjustment: firstly to adjusting bolts, secondly to adjusting, third to adjusting the tight of wedge-shaped belt. Using finger press way, to pressing for 98/N. The standard of crankshaft pulley is 25—31mm. The standard of fan belt is 7—8mm.

(III) Accelerating transmission system

1. Brief description of the structure

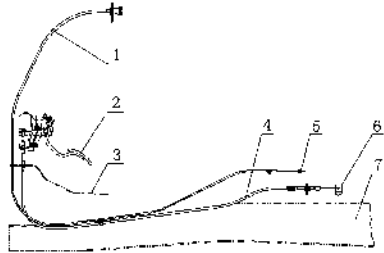

- 1, stalling wire drawing 2, assembly of accelerator mechanism and pedal
3, front floor of the cab
4, acceleration wire drawing
5, stalling oscillating arm of the engine
6, acceleration oscillating arm of the engine
7, frame
schematic diagram of accelerating transmission equipment

Accelerating transmission equipment is composed of accelerator pedal mechanism, accelerator wire drawing and acceleration governor arm of the engine. It is shown in the figure in the above page.

When depress the pedal, driving medium of the mechanism pull the wire drawing, control the opening extent of the accelerator to increase or decrease the speed

1) Accelerator pedal mechanism: Accelerator mechanism take the newest structure of ISUZU truck. It operates simply and reliably and has accelerating wire drawing and hand throttle wire drawing; the pedal is the structure with injected molding and it has the trait of convenient assem-

bling and little operating noise.

2) Accelerating wire drawing:

It operates by the soft wire drawing. And it has traits of reliable structure, convenient layout, little frictional resistance and stable transmission.

3) Hand throttle wire drawing:

Using with the foot throttle can quicken the preheating of the engine or increase the idling speed.

2. Using and adjustment

1) Check the chucking position of the linkage rod and the accelerator mechanism for rightness and reliability, check the direction of the wire drawing for straight and check on the cornering for smooth transition.

2) The pedal should be depressed easily and to the extreme position

without jamming. When releasing the pedal, it should be returned freely.

3) When depressing the pedal, if the free play is too big or the opening extent of the accelerator is not enough, adjust the position of bolts.

(IV) Fuel supply system

1. Brief description of the structure

Fuel supply system is composed of fuel tank, fuel filter, fuel pump, fuel inlet line and fuel return line.

The function of the fuel supply system is to inject the specified quantity diesel fuel of specified pressure and good atomization into the cylinder at the correct time with definite interval of injection according to the operating requirement, and take good com-

pression ignition with the air rapidly. Its operating state has important influence to the power and economy performance of the engine.

1) Coarse cleaner: the car's fuel piping have a DX150T spin-on oil filter, flow volume is 1.5L/min. It can transition impurity and can separate water and oil



diesel precipitator

2) Fuel tank: The tank install the filter gauze inside the fuel filler port to prevent impurity of large particle entering into the fuel tank, set oil drain plug on the bottommost position of the fuel tank to drain the deposit and water on the bottom of tank when cleaning the fuel tank.

Using and maintenance of coarse cleaner

- 1) To tight all the pipe line .
- 2) When the DX150T precipitator works for 1000/km and 200hours, to waterproofing.

III 、Chassis

(I) Clutch

(II) Transmission

(III) Drive shaft

(IV) Rear axle

(V) Frame

(VI) Suspension set

(VII) Front axle

(VIII) Steering system

(IX) Brake system

(X) Wheel & Spare wheel riser

(I)Clutch

1.Brief description of the structure

The clutch equipped for this series truck is single -plate dry type diaphragm spring clutch, outside diameter of the driven plate is $\Phi 254$. The hydraulic control unit of the clutch is composed of the clutch pedal, oil storage cup, release cylinder (master cylinder), wheel cylinder and oil pipe. It is shown in the below figure.

Adjustment of the clutch operating system

1)Adjust the limit screw of the clutch pedal (below figure) to make sure that the free play of the pedal is 3~5mm.

2)Adjust the master cylinder of the clutch: loosen the locknut on the push rod of the master cylinder, rotate the end of the push rod to contact gently the with piston of the master cylinder, then rotate the push rod for 3/4 circle in the contrary direction, tighten the locknut of the push rod, now the clearance between the push rod and the piston is about 0.5~1mm.

3)Adjust wheel cylinder of the clutch
Take off the return spring of the release fork, push the wheel cylinder piston to the bottom of the cylinder, loosen the locknut on the push rod, push the release fork towards the backside of the engine to the position where the release bearing and the release fork contact barely, turn

the spherical nut until it contacts with the release fork, then turn back the spherical nut on the push rod for 3 circles, tighten the nut, install the return spring of the release fork.



clutch pedal

4)Bleed air from wheel cylinder of the clutch

Having air or oil leakage in the hydraulic pipeline of the clutch is unal-

lowed, or else, it can result in the disability of the pedal, deficiency of the effective travel and incomplete release of the clutch etc. So the clutch can not work normally. The work of air bleeding should be completed by two persons in the best, one person depress the clutch pedal in the cab, the other bleed the air in the wheel cylinder. The schematic diagram of air bleeding for the clutch wheel cylinder is shown .

Take off the rubber cap of the air bleed screw on the wheel cylinder, link a plastic pipe on the air bleed screw, put the other end of the pipe into the container filled with brake fluid, depress the clutch pedal several times, fill the master cylinder and

hydraulic pipeline with brake fluid, then loosen the air bleed screw, air bubble can be puffed from the oil ring if there have air in the pipeline. Repeat the above-mentioned operation until the air bubble disappear .

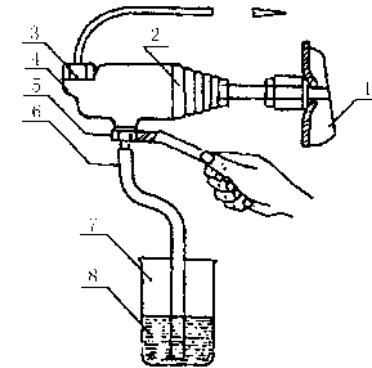

- | | |
|------------------|----------------------|
| 1, release fork | 2, dust cover |
| 3, copper washer | 4, wheel cylinder |
| 5, wrench | 6, soft plastic pipe |
| 7, container | 8, braking |

Maintenance and adjustment

Long time use or incorrect adjustment and incomplete air bleeding of the clutch can bring the halfway release of the clutch, let the clutch on the half contact state for long time, aggravate the wear of the clutch pressure plate and friction linings. The decrepitation, burnt and exfoliation of the friction lining, and the burnout of the release bearing also can result in the abnormal operation of the clutch. When maintenance, all kinds of clearance of the clutch must be adjusted. When doing the third maintenance for the trucks, you must clean general/dispart cylinder and liquid reservoir tank, then fill grease to hole of disengaging shaft.

(II) Transmission

1. Brief description of the structure

The transmission equipped for the chassis of this series truck is manual discontinuously variable transmission with fixed shaft gear, and it has five driving gear and one reverse gear. The synchronizer has been equipped on the second, third, fourth and fifth gear. And the synchronizer is synchromesh gear system. The synchronizer for the first gear and the reverse gear is holding mesh gear. Using of the synchronizer on the transmission can make the shifting operation conveniently, decrease the wear and shock on the gear end, extend the service life of the gear tooth, shorten

the shifting time, increase the average vehicle speed and reduce the working intensity of the driver. The gear shifting operation is accomplished with the shifting control device of the transmission, which is shown in the figure on the next page.

2. Shifting control device of the transmission

The shifting control device of the transmission is long distance soft cable type with high floor and short lever, and it take two flexible shaft to implement the gear selecting and shifting which is shown in the figure on the next page. It is composed of operating lever seat, flexible shaft for gear selecting or shifting and the bracket. The core shaft of the interior flexible

shaft is steel cable, the operation of gear selecting or shifting is completed by the pushing or pulling motion of the steel cable. The ball on the flexible shaft and adjusting screw are used for adjusting the total length of the flexible shaft to ensure that the gear selecting or shifting can be to the correct position. There have symbols of each gear on the control handle of the transmission, it is shown in the below figure.



control handle of transmission

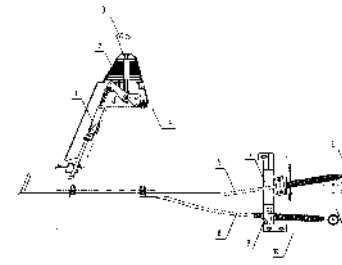

- 1, gear shift control lever
 - 2, dust cover
 - 3, handle
 - 4, floor of the cab
 - 5, flexible shaft for gear selecting
 - 6, transmission rocker arm for gear selecting
 - 7, side bracket for gear selecting
 - 8, flexible shaft for gear shifting
 - 9, fixed bracket of the gear shifting flexible shaft
 - 10, rear cover of the clutch
 - 11, transmission rocker arm for gear shifting
- schematic diagram of the transmission gear shift control device

3. Using and maintenance

- 1) If found the gear shifting can not operate or operates difficultly when the engine is not working, it shows that the gear shifting lever (or the flexible shaft) have bad adjustment or the bolt becomes loose, now you must adjust the control lever (or the flexible shaft), check and tighten every bolt and every nut.
- 2) If found out-of-gear when running on the rough road, the control lever (or the flexible shaft) have bad adjustment, and it should be adjusted correctly.
- 3) If found free play of the control lever too large, check and tighten every bolt and every nut.
- 4) Do not take gear shifting operation

when the engine work at over fast speed to avoid accelerating the wear of the synchronizer.

5) When shifting, the force should be gentle. The hand force must be acted on the control lever until the gear reaches the correct position. Shifting with flap of one push and one loosen is inappropriate and the shifting operation can not be accomplished easily in this way.

6) Only after the vehicle stop and keep steady, the shifting from driving gear to reverse gear or from reverse gear to driving gear can be done, or else, the gear can be damaged.

7) As the fifth gear is over-speed gear, in order to avoid the damage of the overspeed gear spoke, it

running speed is under 50 km/h, the fifth gear can be used .

8) When running, if find there is abnormal noise in the transmission, stop the vehicle and check it, eliminate the malfunction.

9) When sliding on the downgrade, stalling of the engine is unallowed, starting the engine with the inertia of sliding on the downgrade is forbidden to avoid the damage of the gear and the synchronizer.

10) In the running -in period of the new vehicle, because the metal chipping which was produced by the frictional function between new parts is bad to components in the transmission, especially to the life of the conical ring on the synchronizer, so

the lubricating oil should be replaced after the running -in period of the new vehicle expires. Under general condition, for every 6000 km running, replace the lubricating oil once. When replacing the lubricating oil, first drain the oil in the transmission, prop up the rear axle, shift the transmission into the reverse gear, add the kerosene, rotate the transmission for 2~3 minutes, then drain the kerosene, add the pure gear oil.

11) Check the oil level in the transmission frequently, if found the level is under the lower edge surface of the oil filler bolt hole, sufficient oil should be added.

12) Check the outside bolt of the transmission and the flange of the

second shaft for tightness and the operating state of the component in the transmission frequently, because the vent plug is blocked by dust and pressure in the transmission increases, the oil seepage or leakage may be found, so the vent plug should be cleaned periodically.

13) The movement parts of shifting operation should be kept good lubricating, or else, the shifting operation may become difficult because of the wear of the movement parts. If found the position of gear selecting is incorrect, or gear shifting become difficult or the transmission is out of gear automatically in using, firstly you should readjust the gear selecting and gear shifting mechanism.

(III) Drive shaft

1.General structure

The two-piece driveshaft, connected with transmission on the front end and with rear axle on the back end.

2.Use & Inspection

1)Driveshaft has been counterpoised in factory, it should be ensured not to be impacted in use and not to be knocked and stacked in disassemble and carry. Replace if the shaft is distorted or the balancer is desquamated, otherwise there will be vibration, noise, and extra impact in travel, it can damage power train and endanger driver.

2)Regularly check the cross shaft needle bearing, check the sealing of

the slide spline and replace the oil seal when necessary

3)The first maintenance ,to fill grease to universal joint ,slide spline ,oil pistol ,driving spindle and quickly tight the blot in order to sliding the universal joint .According to moment ratio to checking and tighten driving spindle and the middle parts of bearing blots.

The second maintenance ,to checking is there anything fall down about the dirt proof boot ; is there any problems about move the universal joint .when cross shaft in the middle of the needle bearing .The distance would not be very large .If it is too large ,you would be disassemble the universal joint and you can depend

on what you need to changing needle bearing universal joint.

When you do the third maintenance , should be disassemble the driving spindle .Pay attention to sign on flange ,cross shaft ,link fork, slide spline in order to mounting .When you finished all the maintenances , please do the blance check , the standard of dyramic blance is 2750 r/min.The amount of unbalance is more than 144g.cm。

(IV) Rear axle

The brief of structure :Single reduction rear axle ,as the final part of power train of truck ,is the driving axle ,and it is composed of final drive and differential and axle housing .Final drive can not only change

the direction of driving force ,but also reduce the rotate speed .It is composed of drive pinion and driven gear and final drive .The drive pinion is composed with drive shaft ,whose end with spline is connected with universal joint assembly by coupling flange .Center support is mounted in two opposite conical bearing ,so that it can suffer not only radical bearing , but also axial force. Drive pinion, whose small-end journal mounted in direct tapered roller bearing, can only support radial force. It is fixed on the flange which located on top left of differential case by several bolts. A differential, composed of differential case and cross and four side pinions, let the left wheel rotate at a dif-

ferent speed from the right wheel. Rear one -piece banjo style axle housing is made by means of welded punched armor plate. Meshing of tooth face and clearance adjustment of final drive
(1) Check drive pinion bearing for pretension .The pretightening force of drive pinion bearing should be adjusted. Measuring in the bolt hole of drive pinion bearing case, the tangential pull should be 15~30N.
(2)The pretightening force of drive pinion bearing can be adjusted by means of adding and reducing adjusting shim. Add shim can decrease friction torque, while reducing shim can increase it. There are three kind of shim according to thickness

(0.40mm, 0.45mm, 0.5mm).
(3) Check final drive for meshing between drive pinion and driven gear. The contact area and side play between drive pinion and driven gear can be adjusted by means of adjusting shim and adjusting collar of differential bearing. There are three kind of shim is 0.30mm and 0.4mm 0.45mm, and the 0.5mm Normally, the clearance between these two gears is 0.15~0.25mm, while the side play ranges under 0.07mm. To adjust side play, measure four points with equal angle around the driven gear, and the gauge outfit of micrometer should be in a vertical position. To adjust tooth contact area, driven gear should be coated with red lead at

three points, and 2~3 teeth should coated at every point. Then rotate gears clockwise and anti-clockwise to get the trace of contact area (see the right figure).

The teeth area is not suit the figure (a)which should be adjust it .If the trace is slanting to the convex or concave then adding the shims ;if the trace is slanting to the convex or concave ,then reducing the shims.

Normal trace should be near the small end ,as figure (a):Add shim if trace near the convex or concave tooth root ,as figure (b);Reduce shim if trace near convex or concave tooth top , as figure (c).

Adjust the wheel hub bearing of rear axle: to locking bearing and nut ,then

release1/3—1/4circle。 Tighten the force moment to 490—588N.m

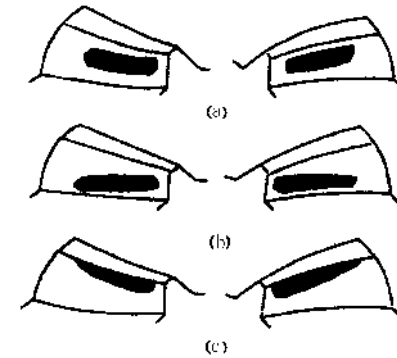

Use & maintenance

- 1)Lubricate for hyperbola bevel gear is very strict, can be only specified gear oil. Don't use or mix with other gear oil, or will result in quickened scratch and wear.
- 2)Don't remove or adjust the gears

and bearings of final drive, for they have been matched and adjusted in factory. Do these only when gear worn and free play is beyond the limit value, or when bearing axial clearance is beyond the limit, or when some of parts damaged.

3)Clean the vent plug regularly, make sure that ventilation is expedite. A jammed air drain can bring higher air pressure in rear axle, and it will result in lubricant leak from the drive pinion seal and other welding line.

4)Check the lubricant level in axle housing regularly. Check the lubricant for quality regularly, and replace if the chroma and viscosity is abnormal.

5)Finished the third maintenance, disassemble the back cover .Then clean cavity and main reducer axle . To tight the fore moment nut and blot.

(V)Frame

The brief of structure :This kind of truck's chassis is across structure Use & Maintenance :Using longitudinal beam and cross beam is to fixed the frame .Using weld and screw thread to connecting .So ,keep all the parts well to exerting the advantage of the frame .When doing the third maintenance checking , if the screws are lax that should be tight it. If the cross beam have something wrong , should be mend it .

The reason of damage the frame is

overweight , parking position and road and so on. .So ,must following the request to driving .

(VI)Suspension set

General Structure: The suspension of this series of trucks is composed of multiply variable leaf spring ,bidirectional hydraulic telescopic shock absorber and transverse stabilizer. Rear leaf spring is composed of main spring and secondary spring, its stiffness changes little by little, so that vehicle is more comfortable for ride.

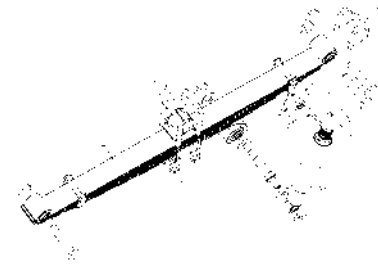

- 1. Front leaf spring
 - 2. Front U bolt
 - 3. bumper
 - 4. Front shackle
 - 5. Upper bracket of front suspension
 - 6. Front absorber
 - 7. nut
- front suspension assembly

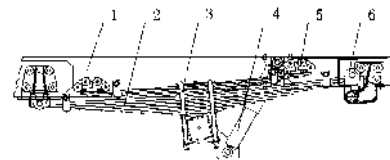

- 1, Frame
 - 2, Rear leaf spring
 - 3, Rear center bolt
 - 4, Rear absorber
 - 5, Secondary spring bracket
 - 6, Rear shackle clamp
- rear suspension assembly

2. Use & Maintain leaf spring

1)At the beginning of running-in period, check the nut on U -type fastening bolt and tighten it with specified torque when trochometer points to 200km and 500km.

2)After running-in period, tighten the nut on U -type fastening bolt with specified torque (with vehicle fully loaded). Do it also when leaf spring is replaced or reset.

3)Tighten the nut on U -type fastening bolt with specified torque (with vehicle fully loaded) every 2000 ~ 3000km.

4) The first maintenance, Check and tighten bolts and nuts in your touch on suspension. Check the rubber parts on the suspension and replace

if too much wear.

5)At the second maintenance, doing the first maintenance items .Then disassemble and lubricant the spring of plate , at the same time to checking anti-roll stabilizer .

6)At the third maintenance, doing the second maintenance items . Then disassemble all of the rubber to changing the news.

7)Take notice of the orientation when replace leaf spring or operate on the center bolt. Tighten each nut first, then tighten nuts on front U -type fastening bolt with specified torque before tighten the rear ones.

3. Use & Check absorber

1) Check the absorber for temperature after running a length on bad

road surface (commonly more than 10km). Absorber don't have resistance if the temperature lower than condition temperature; if one absorber have much lower temperature than the symmetrical one, the lower one's resistance is much more smaller. Lower resistance result from lack in oil or from damage of some important part, and the absorber that lack in resistance should be removed to inspect.

2) Check the absorber for oil leak if continuous abnormal vibration is detected. Oil leak should be dealt with on time, so that the absorber can work normally.

3) Check absorber when maintaining vehicle. To check absorber, stick up

it and hold its lower end by vise, then pull and press it for several times. Normally the resistance is bigger when pulled, otherwise the absorber is damaged or lack in oil. In the case , to changing and mending the parts ,then fill oil into shock absorber .In order to absorber parts.

4) Always replace the oil seal when you replace absorber rod. Don't disassemble parts such as valve if unnecessary.

5)At the third maintenance ,disassemble the shock absorber and changing the new oil .Do not clean the shock absorber.

(VII)Front axle

1. General structure

Front axle assembly is composed of

front axle, steering knuckle, steering knuckle king pin, hub and tie rod. See the next figure.

The front axle is I-beam. The toeing-in is 3~6mm (diagonal tire) and 1~3mm (radial tire). Proper orientation can make sure the vehicle stable and easy to control, so that can lessen driver's fatigue and slower tire wear.

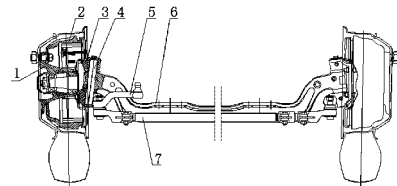

- | | |
|--------------------|---------------|
| 1,Front hub | 2, Brake drum |
| 3,Steering knuckle | 4, King pin |
| 5, Pitman arm | 6, Front axle |
| 7, Tie rod | |

front axle assembly

2. Adjustment

1) Adjustment of front hub bearing. To adjust front hub bearing in axial retightening force, tighten fastening nut with wrench, and loosen knuckle nut for about 120o. Rotate the hub clockwise and anti-clockwise, make sure that roller against the tapered face of bearing outer race properly, then tighten nut to the position where the rabbet aims the split pin hole. Check the hub if it can rotate freely and don't swing a lot. Now, distort the split pin and fix it.

2) Adjustment of clearance between knuckle and front axle. The clearance is adjusted via adjusting shim, it should less than 0.1mm.

3) Adjustment of toeing-in. The toe-

ing-in can be adjusted via adjusting tie rod. Park the vehicle on a flat ground, jack up its header and orient front wheels just as vehicle run forward. Loosen locking nuts of tie rod, rotate the tie rod until the toeing-in fit the specified size.

Use & Maintenance

1) The first maintenance .When doing the first maintenance ,check the nut tightly.

2) When doing the second maintenance to checking damage about steering knuckle , steering knuckle pin bearing ;to checking about steering knuckle arm ;to checking about steering drag rod .According to the regulate ,disassembly wheel hub and fill grease with it.

3) when doing the third maintenance ,to disassembly the front axle then cleaning and checking it.

a) If the distance between steering knuckle and front axle is very large , should put a thrust shim on it to adjusting .The distance is 0.1mm to be good.

b) When the steering knuckle pin and the bush's distance is 0.15mm, then to change new ones.The damage distance of the steering knuckle pin is to 0.07mm,changing new ones.

c) The damage of steering drag rod ball end and ball end is too big ,then change the new ones.

d) When find out the damage of oil seal of the wheel hub , then change the new ones .

(VIII)Steering system

General Structure:The steering system of this series of truck is power steering system.

Power steering

The steering system composed of steering control mechanism, linkage mechanism ,whole power steering gear ,power steering pump and pipeline.

The energy source of the steering system is depended on driver's physical strength and power of engine .In some emergent cases about steering system that the driver can control the direction .To compare with some common machine steering system , the power steering system is very sensitive and secure.

Operation Inspection for Steering Mechanism

- 1) Put front wheels on a swivel table.
- 2) Rotate steering wheel clockwise and anti-clockwise to its limit position, to detect if it is fluent.
- 3) Let engine run in idle speed and check steering wheel for free play. The limit value of this free play is 15~35mm. Rotate the adjusting screw clockwise to decrease the free play, while rotate anti-clockwise to increase.
- 4) When engine run in idle speed, the torque of steering wheel should be around 19.6N.
- 5) When starting the engine to turning steering wheel to two sides for several times. When removing the air from

the engine, then fill oil into it.

- 6) Turning the steering wheel to the front.
- 7) Turn off the engine to checking oil. If it need oil, then fill it.

Note: To checking is steering oil on a high temperature. If it has some troubles, then doing the 4 and 5 steps again or mending power steering pump.

Use and Maintenance

- 1) Check the new truck to driving for 3000—4000km, then fill oil to steering and cleaning oil net.
- 2) Always checking the oil measure or oil quantity in the oil crotch, if it has something wrong that change it.
- 3) Do not disassemble the steering system for another side. Pay atten-

tion to the oil pump pipeline, it can not fill with air in it. Keep cleaning it.

Step:

- a) Turn the steering out oil pump into the steering in oil pump.
- b) The return oil inlet connect with oil-can inlet.
- 4) In some troubles of power steering, the driver can use the hand steering but could not use for a long-time.
- 5) Don't steer when parking, since it will shorten useful life of parts.
- 6) According to the regulate to fill hydraulic pressure oil, the environment temperature is above 0 °C, change steering system should adopt L-HM 464# wear resistance hydraulic pressure oil; the environ-

ment temperature on 0 °C. (the different number oil can't mix an usage). The import power steering or steering pump to choose to press oil with the DEXRONII model number liquid. (American G.M. standard)
The use and maintenance of power steering

1) How to use of power steering

- a) Don't steer when parking for 5 minutes.
- b) Forbid to steer the steering wheel when can not moved.
- c) Forbid to steer the steering wheel in the same place.
- d) Forbid to steer the steering wheel speed for 90turn/m.

2) How to maintenance of power steering

The main idea is to prevent, to check for scheduled time. Following about the ministry of communications standard about the car JT/T201—95《The arts and crafts maintenance of car》 and city build ministry standard CJ17—86 《The technique condition mending way of the city bus》.

- a) Daily maintenance: to checking the truck when driving in order to your security.
- b) One class maintenance (2000-3000 kms)
 - i. Each lubrication part to fill the grease, the power steering should be fill the oil on time.
 - ii. Insure cross shaft, cross/lax pull rod ten ball end to moved vivid and not loose.

- iii. Check tight each conjunction part.
- iv. Check pipe conjunction part, insured and don't leak oil.
 - c) Second class maintenance (10000-15000 kms)
 - i. Change the power steering oil.
 - ii. Clean and check the steering wheel.
 - iii. Clean the power steering oil net.
 - iv. Check front axle, ball axle, steering knuckle, steering knuckle arm, steering knuckle frame.
 - v. Disassemble, length pull rod, cleaning and checking parts in order to insure them well.
 - vi. The other parts, please read the reference. (JT/T 201—95)
 - d) To install steering knuckle plumbing arm and locate bolts. The daily

maintenance:

- i. Insure the location. Find out steering knuckle plumbing arm is fall, then put them on.
- ii. If the steering knuckle plumbing arm have some mistake, change the new ones.
- iii. Tight the steering gear and frame, frame and frame blot.
- iv. When turning the direction, insure the length pull rob and steering knuckle plumbing arm do not inter-vene for each other.

(IX)Braking system

Braking systems of trucks of this series are: parking brake system(center drum) and running brake system (air brake, hydraulic brake)

1. Running brake system

1.1 Air brake

1) Brief description of this system:

Compared with hydraulic brake, air brake can bring greater braking force under the condition that force on the pedal is not great and the pedal stroke is not long; at the same time, dual-circuit air-pressure driving braking device is equipped to front and rear wheel separately, so the braking is safe, reliable, labor-saving, and more effective; even if one of the brakes does not work, the vehicle can still brake safely.

2) Structure and theory (referring to the following diagram)

Brake pipeline is arranged as follows: compressed air produced by

air compressor 1 comes into the main air reservoir 3 (namely wet air reservoir); and then the air is separated into two and come into the front chamber 9 of the auxiliary air reservoir and the rear chamber 4 of the main air reservoir. Compressed air in the front chamber 9 of the auxiliary air reservoir and the rear chamber 4 of the main air reservoir come into upper and lower chambers of brake valve 8, and then the air is transported separately to rear brake chamber 12 and front brake chamber 2. Check valves 10 installed on ends of the air inlet pipes of the front chamber 9 of

the auxiliary air reservoir and the rear chamber 4 of the main air reservoir in case that compressed air in the air reservoir flows backwards. There are interfaces for air pressure gauge 7 and pressure-adjusting valve 6. When air pressure reaches 0.74 - 0.84Mpa, compressed air props up valve of the pressure-adjusting valve, and comes into upper cover of the air compressor to make air inlet valve open and the air compressor idles. When brake valve 8 is depressed, front and rear brake chamber 2 and 12 operate at the same time, which makes front and rear brakes operate. When the brake pedal is released, compressed air in front and rear brake chambers go in-

to the atmosphere by front and rear air-deflating valves 11 and 13.

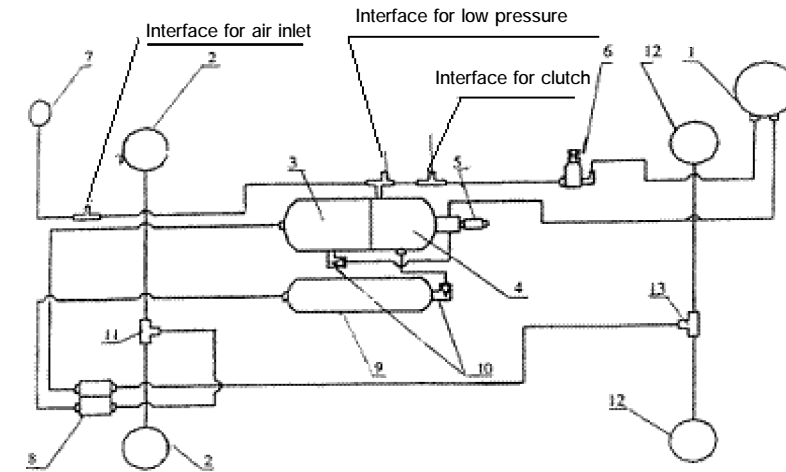

1. air compressor; 2. front brake chamber; 3. front cavity on main gas cylinder
4. rear cavity on main gas cylinder; 5. safety valve; 6. pressure control valve
7. barometer; 8. brake valve; 9. additional gas cylinder; 10. one-way valve
11. front quick-release valve; 12. rear brake valve; 13. rear quick-release valve

Brake assembly

The function of brake is to utilize power produced by friction between brake drum and brake shoe slice to absorb kinetic energy of vehicle to decelerate or stop the vehicle. Front and rear brakes of this brake system adopt imbalanced structure and are mainly composed of brake chamber, brake arm and brake

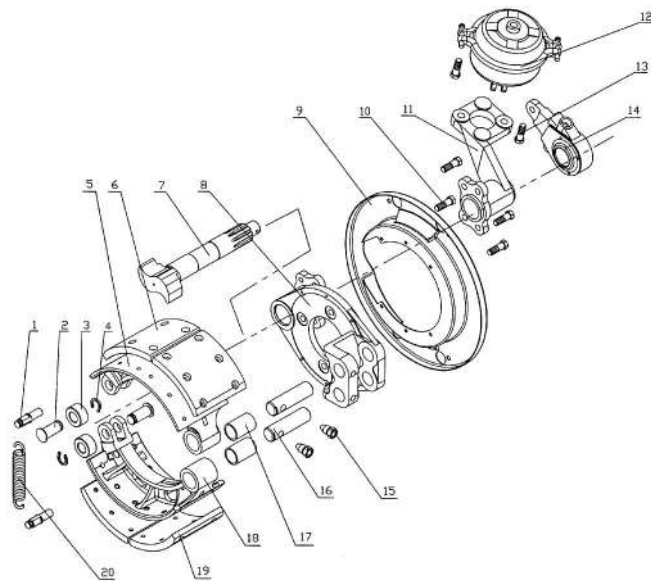

1. return spring locating pin; 2. roller shaft-brake shoe
3. roller-brake shoe; 4. gripping ring-brake shoe roller shaft; 5/18. front brake shoe with liner assembly;
- 6/19. front brake friction plate; 7. brake cam; 8. front brake baseboard with liner assembly; 9. front brake dust cap;
10. hex bolt; 11. front brake air chamber support frame with liner assembly; 12. front left brake air chamber assembly;
13. hex bolt; 14. front brake adjusting arm assembly; 15. shoe shaft fixed bolt; 16. front brake shoe-shoe shaft;
17. front and rear brake shoe shaft-liner; 18. return spring

Adjusting arm

1) Lubrication: mount oil month on adjusting arm, use lithium base grease periodically to lubricate adjusting arm (maximum lubrication interval is limited to 10000km), or else, life of adjusting arm will decrease.

2) Check adjusting arm's counterclockwise force moment periodically: rotate adjusting nut of adjusting arm counterclockwise when running every 20000km and measure whether the rotary moment is bigger than 18Nm, measure for three times repeatedly. If the moment is smaller than 18Nm, it indicates adjusting arm has been damaged and needs to be replaced the adjusting arm assembly.

Brake

Front brake has the same structure with the rear brake. It is shoe brake with camshaft with fixed sustainer. When braking, front and rear shoe slices of the brake press to the rotating brake drum by the action of the same push force; so the rear brake shoe is called power-reducing brake shoe. All above lead to imbalance of forces that front and rear brake shoes press on the brake drum, so this kind of brake is called simple imbalanced brake.

Clearance between friction disc of the brake shoe and the brake drum must be proper, before adjusting the clearance, make the front wheel off ground; adjusting steps are as follows:

Full adjustment

1. Loosening fixed nut of brake shoe bearing pin and nut of binding bolt on cam bracket.
2. Rotate brake shoe bearing pin so as to make clearance between front shoe and bearing pin end the same as that between rear shoe and bearing pin.
3. Start braking, make brake shoe friction disc lean against brake drum closely and brake camshaft automatic positioned and tighten nut of binding bolt on support frame.
4. Release braking and rotate worm so as to make brake shoe friction disc lean against brake drum closely. Then counter-rotate worm, released by 3/4r, brake drum should be rotate

freely.

5. Test drive after adjustment, check working condition of brake, whether the brake drum get hot and whether braking distance is proper. If not, readjust it

Parts checking

To move the worm of brake arm to adjusting the distance between brake assembly and brake drum . The way: to the worm for clockwise and move it again and again when it can moved. Then move the worm for counter -clockwise to 1/2—3/4 circle. At last the brake drum work agility . The distance between brake friction piece and brake drum is 0.25c—0.4mm, camshaft is 0.45mm.

Brake valve

Brake valve is to adjust and control the whole brake system.

Use and maintenance

1) Take care of it

a) Should check the tube pressure before driving, be air pressure measure is 0.6 MPa square can drive, while driving in normally is in the 0.74 - 0.84 MPas, should park the car whether leak air or not and whether the compressor normal work or not.

b) When driving the truck to check brake system. If it has something wrong should be change it for another one.

c) The damage of the brake shoe plate is too big, then changing another one. The piece should be the

same new ones and do not have dirty oil, shatter, chap.

d) To change the friction and install shoe plate and brake cam again in order to adjusting the friction piece and the brake cam.

2) Schedule time maintenance:

a) The first maintenance (1500-2000 kms)

i. To excluding the oil from the gas cylinder.

ii. To fill with grease where need it.

iii. To checking and adjusting the tighten about air compressor .

b) The second maintenance (10000—12000km)

i. Disassemble and adjust the brake and adjust the distance between brake shoe friction piece.

ii Check the air compressor and clean the dust of air valve.

iii. Check the brake involuca which needs news to changing it.

c) The third maintenance (24000—30000km)

i. Check and adjust the brake valve .

When it need new one then change it

ii. Check the brake valve pipe .

When it need new one then change it

iii. Clean all the pipe in order to keep it liquidity.

1.2 Hydraulic brake system

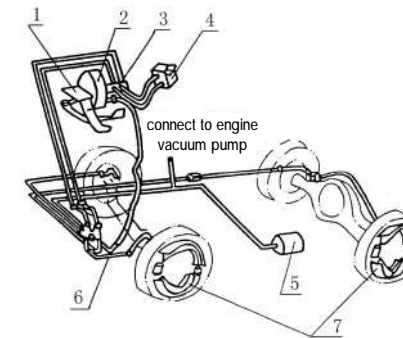

- 1、Control mechanism
- 2、Vacuum booster
- 3、Master Cylinder
- 4、Reservoir
- 5、Vacuum cylinder
- 6、Brake tube
- 7、Front & Rear brake

the picture of running brake

1) General Structure

The running brake system is hydraulic. It is composed of vacuum

booster, vacuum cylinder, master cylinder, control mechanism, brake tube, front brake and rear brake. It is sensitive and reliable, and it is simple to manipulate. See the last figure. If you feel braking power is not sufficient when brake pedal is depressed completely and oil level is normal, there may be air in brake system. Bleed system in follow sequence. Firstly, bleed RR brake; secondly, bleed LR brake; thirdly, bleed RF brake; then bleed LF brake. Follow these steps:

a. Clean air -drain screw of main cylinder and wheel cylinder;

b. Remove oil -drain plug of main cylinder or reservoir and fill it with brake fluid until fluid level reach the

edge.

c. Depress the brake pedal several times before hold it depressed and release the air—drain screw to bleed. Repeat doing this until air in tube be bled completely. Keep a little oil left, or air can reenter the system.

d. Fill reservoir with brake fluid.

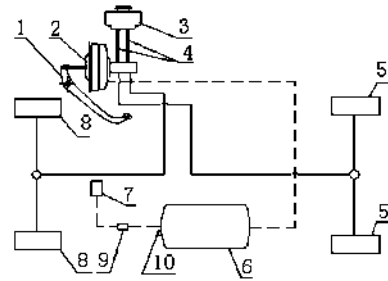

1. Brake pedal 2. Vacuum booster and main cylinder assembly
 3. Reservoir 4. Connection hose
 5. Rear brake 6. Vacuum cylinder
 7. Intake manifold 8. Front brake
 9. Vacuum check valve
 10. Connect to vacuum-alarm
 —hydraulic tube- - -vacuum tube

schematic diagram hydrostatic brake system

2) Note When Use Brake Fluid

- ① The specified brake fluid of this series truck is synthetic brake fluid of class JG3 (GB10830).
- ② Never use mixed brake fluid.
- ③ Synthetic brake fluid is good at sopping up. They should be storage in a clean sealed dry container, keep away from water, organic solvent, petroleum, and dust. Otherwise the vehicle's capability of brake would be cut down seriously.
- ④ Clean system with alcohol before replacing brake fluid with different brand. Follow these if alcohol is unavailable.

a. After drain all old brake fluid, fill reservoir with new fluid near to the opening and bleed system again, in

order to sweep old fluid away.

b. Fill system with brake fluid.

⑤ Brake pedal's free play should be 5 ~8mm after adjusted, or it will cause main booster work abnormally and make brake drum over hot.

Running brake

1) General Structure

The running brake is hydraulic drum, both front and rear is two leading shoe brake. It is composed of bottom plate, wheel cylinder, brake shoe set with pad, and return spring set.

2) Adjustment of Running Brake

The clearance between pad and drum will be bigger and bigger due to wear. In order to ensure brake work well, adjust it regularly follow these steps.

Jack up the wheel which you want to adjust and remove the seal plug. Dial the adjusting gear of wheel cylinder piston accord the arrow near the adjusting hole on bottom plate with special adjusting screw and at the same time rotate the brake drum until the drum can not rotated by hands. Then rotate the adjusting gear back for 5 ~9 teeth, keep the pad 0.2 ~ 0.45mm away from the drum, so that the drum can rotate freely again.

3) Use & Check

Replace the pad which is worn out or damaged. Before installed, the new pad should be ground. Make sure that the new pad has not oil coat, also has not crack and chap and other flaw.

The clearance should be adjusted in every time of maintenance. Check drums with hands for temperature every time you park, adjust the clearance if the temperature is too high. Check wheel cylinders for leak, and replace the leather gasket if leak is detected. Protect drums from being wrong result from over heat and other reason.

Vacuum booster

1) General Structure

Booster of this series of truck is dual diaphragm vacuum booster, which is composed of return spring, control valve, rubber diaphragm, noise elimination board, and so on.

2) Adjustment

Booster have been adjusted in fac-

tory, don't disassemble it and protect the diaphragm from been damaged.

1.3 Parking brake system

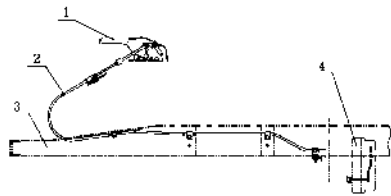

1,Control lever 2,Pull wire
3,Frame 4,Parking brake

parking brake system
control mechanism

The parking brake system includes control lever, pull wire, and parking brake, as the last figure. Parking brake, which is mounted next to transmission, is center drum brake. It can act on drive shaft when vehicle

is parking. Also it can operate with running brake together in emergency.

2) Adjustment

Normally, the clearance between parking brake drum and brake pad is 0.65mm, and it is homogeneous in upper and lower parts. The pad should be replaced often. Follow these steps.

- Jacking up rear axle until one wheel deviate from ground.
- Release the brake handle completely, shift gears to neutral position.
- Rotate brake drum until the hole gets its lowest position. Insert a screwdriver through this hole to stir the adjusting nut upward until brake drum braked completely

Then return the adjusting nut for 2~6 teeth. See the right figure.

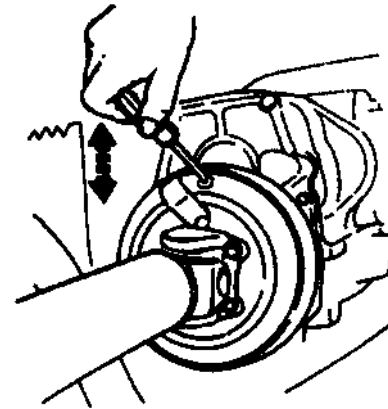

adjustment of the clearance between
brake pad and drum

Use & Check:

Check and adjust the clearance between brake pad and drum.

(X)Wheel & Spare wheel riser

General structure:Every truck has seven wheels, one of which is spare tyre.

Use & Check:

In order to use for a longer time, please charge tire according to specified pressure value. Never drive when pressure is insufficient. It is normal that pressure increases during travel, and don't try to reduce it by deflating. Check the tire pressure when tire is not hot. If the two center patterns on tire tread touch against ground under fully loaded, the pressure is normal. Clean the rust and other dirty on rim

before installed. It should be talced on the surface between inner tube and outer tire. Wheel nuts should be tightened for two steps. Tighten all of them first before tighten them with specified torque according to diagonal sequence.

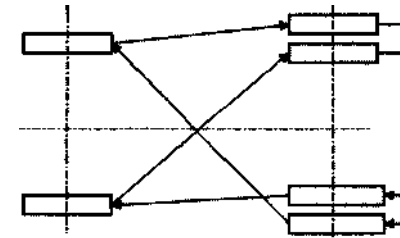

In order to make tires wore uniformly, exchange wheels each other according to the figure.

2. Spare wheel riser

1) General Structure & Use

The spare wheel riser is driven by catenary suspension internal geared wheel, see the next figure. It is mounted underneath the frame. To operate it, fix it on the frame and tighten it with hand before rock back for 15 degree.

2) Maintenance of Riser

Check riser for loose every time before drive. Check chain and carrier spring for crack and replace if necessary. In order to prevent it from rust, grease the gearing regularly, so that it can be easy to operate. The third maintenance, should be prepare wheel.Then cleaning,checking ,install it again.

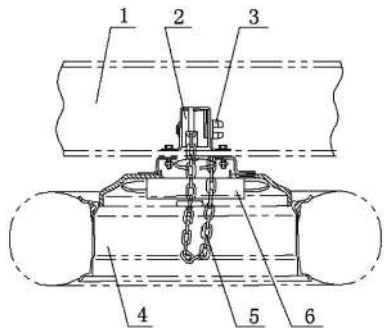

1,Frame 2,Spare wheel riser assembly 3,Eccentric wheel
4,Spare wheel 5,Chain 6,Carrier spare wheel riser set

IV、Electrical equipment

- (I) Starter
- (II) Generator and adjuster
- (III) Illumination equipments
- (IV) Battery
- (V) Sensor

(I)Starter

Note:

- 1) Starter should be connected with battery correctly.
- 2) Every time start, don't keep starter work continuously for more than 15s and stop for 1-2 seconds in the interval, since over hot may damage it. Rest it before try start once again.
- 3) After several continuative failures, check starter, solenoid switch, battery, wires, and also oil supply system. Retry after trouble is shot.

(II)Generator and adjuster

Note:

- 1) Generator should be connected with adjuster correctly, and the polarities of generator and adjuster

should be matched properly.

- 2) Never check generator by short-circuit fire wire and magnetic field.
- 3)The diode and insulation of generator can be inspected with multimeter and ohmmeter. Don't use megohmmeter to inspect, also AC power whose voltage exceeds 200v.

(III) Illuminate equipments

1. Headlamp

This series of truck have two headlamps which are embedded in front of cab symmetrically. The headlamp which is called double filament bulb has two different pieces of filament and can shine two different kinds of ray, the brighter one is used as high lamp while the dimmer one is used as low lamp. Running in night, turn

on the high lamp to lighten the road, but switch to low lamp when two vehicles pass each other.

In order to see the road clearly , when you stripping and re-assembly headlight that you could be adjustment the position . The way is to put the car on a evenly road then put a screen in front of the car. The distance between the car and the screen is about 10meters.(as picture)



headlamp(new series)

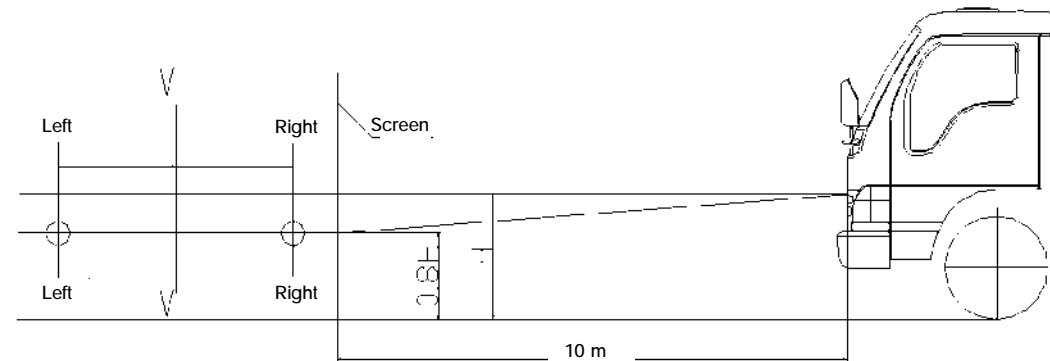

headlamp(old series)

Use the measuring cell to testing. Put the car and the measuring cell

for a line, from measuring cell screen to testing left, right, the far and near light beam to project light upon directions to be partial to move a value respectively.

To adjusting the headlight' the uprightness and the level. To adjusting the passing beam , make it match diagram the shining area center re-

quest a left and right light to left and right (the V is left-the V is left, the V is right-the V is right for the middle point) be partial to move a value to be no bigger than a 100 mms.

2. Small light

Two small lights are embedded on the two symmetrical corner of front panel. They should be turned on

when vehicle park in dark or fog, also when run in day to show the position and the width of the vehicle.

3. Fog lamp

Fog lamp can light further in fog than other lamp. They should be turned on when vehicle run or park in fog or in dark, so that vehicle can be seen clearly. Fog lamp is combined with headlamp.

4. Ceiling lamp

The ceiling lamp is installed on the ceiling, and it is combined with inside rear mirror together. It can light on the cab, and also it can observe the condition behind.

(IV)Battery

1. General

The battery of this series is aneroid, and it is sealed by a plastic case. This kind of battery has a big capacity and a light weight.

2. Use & Note

1) Keep the case clean, and protect battery from leak.



2) Make sure that the hole on the upper cap not choked, or the plate will be damaged by the vapor produced own to electrolyzing.

3)The electrolyte level should be 10~15mm higher than plate. Only distilled water can be filled into battery.

Never fill battery with fountain or river water, for them will do harm to it.

4)Check the electrolyte for specific gravity and level. Do it every 10~15 days in winter, while do it every 5~10 days in summer. Specific gravity is measured with gravimeter. Table 1 shows normal specific gravity of electrolyte.

5)The battery should always being charged. Check battery for electrical voltage if engine is hard to be started. Additional charging if it is detected that specific gravity of electrolyte lower than 1.18 ~1.20, or battery plates will be vulcanized and it will do harm to the plates. Additional charging should be held for 13~16 hours, and it can breathe 1/10 of ca-

pacitance into battery. Cut down the charging current for half after single cell's voltage reaches 2.4V. After charging battery for 3~5 hours, if the specific gravity of electrolyte don't rise any more, keep on charging for 2~3 more hours. Table 2 shows the relationship between temperature and the corrected specific gravity value of electrolyte.

6)Protect the joint of terminal post and wire from dirt and loose, or the terminal post will be burnt. Applying a Vaseline coat on the terminal post after tighten the joint which can protect joint from rust and loose contact, so that engine can be started easily.

7)If left unused for a long time, battery should be removed and pre-

served in a place where is dry, shady, cool, and ventilative And do the additional charging every month.

Table 1 Specific gravity of electrolyte

Loca	Specific gravity of fully charged battery under 15°C	
	Winter	Summer
Where temp below -40°C in winter	1.310	1.270
Where temp above -30°C in winter	1.290	1.260
Where temp above -20°C in winter	1.280	1.250
Where temp above -10°C in winter	1.270	1.240
Where temp below 0°C in winter	1.270	1.240

Table 2 Corrected specific gravity value of electrolyte under 15°C

Measured temp of electrolyte	+45°C	+30°C	+15°C	0°C	-15°C	-30°C	-45°C
Corrected value on hydrometer	+0.02	+0.01	0	-0.01	-0.02	-0.03	-0.04

(V)Sensor

1. Fuel level gauge sensor

The fuel level sensor is sliding resistor. Floating on the fuel level, the float rises and drops with the level's change. This change causes the resistor connected in circuit and shorted, and make the electromagnetic fuel level gauge changes. Connecting the fuel level alarm lamp's terminal with the indicator light can shows the lowest fuel level.

2. Water temp sensor

The temp sensor is a thermistor which is mounted in water jacket to detect the temp of cooling water. It is connected with the water temp gauge on instrument board. The wa-

ter temp sensor has a negative temperature coefficient and its resistance decreases with the increase of water temperature. Don't replace the sensor with a positive temperature coefficient one, or the water temp gauge can not work correctly.

3. Oil pressure alarm

Oil pressure alarm is a normal closed switch. It will be opened when oil pressure reaches and over the lowest pressure, so that circuit is disconnected and indicator goes out.

V 、Vehicle service and maintenance

- (I) Notice during running-in period
- (II) Daily maintenance
- (III) Second-class maintenance
- (IV) Seasonal maintenance

(I) Notice during running - in period

To improve vehicle's reliability and economical efficiency and also to use it longer, follow these during running-in period which is specified as about 2500km.

1. Before running-in period

- 1) Wash vehicle with water, and check all bolts and nuts for tighten.
- 2) Check the radiator for enough water, and check the engine, transmission, rear axle, and steering gear box for enough lubrication, also check battery and reservoir for liquid level.
- 3) Check brake system, drive system, and steering system for correct operation.
- 4) Check electrical equipments and

lamp instruments for correct operation, and check brake system for normal air pressure.

5) Check the shift gears for right; the control parts for normality, transmission for shifting smoothly, and the indicator should work correctly.

6) Check tires for proper air pressure.

7) Check that if driver tools and accessories are taken.

2. During the running-in period

1) The new truck should run on smooth road, and don't make it load more than 50% of its rated load before it traveled 800km and don't load more than 75% before 1500km, or it will shorten truck's life and bring driver danger.

1) Put so many goods in the trucks, it will be curtail the car's life and also influence your safety.

2) Don't run faster than the follow speed.

First gear	7km/h
Second gear	14km/h
Third gear	26km/h
Fourth gear	40km/h
Fifth gear	56km/h

3) At the beginning, check the rear axle, transmission case, driveshaft, and brake drum for temperature. Give ear to the sound of chassis when driving and stop to inspect if abnormal noise is heard, then shoot trouble before drive again.

4) Both the cooling water temp and oil pressure should be noticed very

well. Don't drive in high speed when the temp is below the normal temp (between 80°C and 90°C).

5) Regularly check the engine cylinder cover, wheel nuts, car body, and the U-bolt of leaf spring for tighten. Check the steering system, brake system, and clutch for normal operation. Check steering wheel for free play. Check the brake pedal and clutch pedal for operating stroke and free play.

Note: Cylinder cover bolts should be tightened twice when the cylinder is cool, according to diagonal sequence from the center to sides.

6) The oil should be replaced after 500km, 1000km, 2500km (do it when engine is hot), then it will be repl-

aced again in second-class maintenance.

3. After running-in period

1) Replace engine oil and oil filter core. Replace oil in transmission case and rear axle, and replace lubrication in steering gear, also hub bearing grease.

2) Check all external bolts and nuts with specified torque.

3) Apply grease on all points where should be lubricated.

4) Do items of first-class maintenance.

(II) Daily maintenance

When you find out some mistakes about the trucks, you must check and resolve it at the first time. It is very important to do periodical

service for the truck. As a result of the area and periodical service are different, so you should be take care of the truck to periodical service.

The following references is how to take good care of the chassis. Does not introduce about the season service. User can follow the basis about area to do season service.

Everyday routine maintenance
Everyday you do not use the truck, you may check about it, in order to having a good technology.

1. To checking the engine and fill with rust prevention and antifreeze coolant. In winter, let out water from the engine. If you want to using antifreeze coolant that you must follow the air temperature.

2.To checking the measure lubricant oil of the engine.

3.To checking the degree of tension and measure of injury about the fan belt.

4.To checking brake system when it was working or sealing the atmospheric pressure (hydraulic pressure) and pipe line.

5.To checking the work about direction system circumstance, whether each bolt and the nut hasn't loosen to move.The cotter pin is very tight.

6.To checking weather the spring about armor plate

7.To checking the atmospheric pressure of wheel.To finding where is harmful position about the wheel and

nut.

8.Notice to fill water to the air reservoir everyday.

(III)Second -class maintenance

When the new car was driving for one period which should take daily care and scheduled care.In order to understanding the basis usage and the technology.The car drive on a common road,the second maintenance mileage is 15000 kilometers. The car is going to do the second maintenance,you can come to JAC Special Repair Shop and we will try our best to help you.

(IV)Seasonal maintenance

In order to keep some parts meet the requirements of climate on aspects

of technique and work request, do seasonal maintenance.

At the beginning of summer:

1. Cleanout water scale in the coolant system.

2. Replace lubrication for summer.

3. Fueling with #0 diesel oil specified in GB252.

4. Clean up the battery and adjust the specific gravity of electrolyte.

At the beginning of winter:

1. Clean up the battery and adjust the specific gravity of electrolyte. Then remove and charge it.

2. Install cold proofing devices, also kid prevention devices if necessary.

3. Fueling with #10 diesel oil specified in GB252.

VI \ Trouble shooting

1.Electrical parts trouble shooting

2 \ Clutch trouble shooting

3.Drive shaft trouble shooting

4 \ Transmission trouble shooting

5 \ Front axle trouble shooting

6 \ Rear axle trouble shooting

7 \ Steering mechanism trouble shooting

8 \ Running brake trouble shooting

9 \ Parking brake failure shooting

10 \ Suspension set trouble shooting

11 \ Wheel trouble shooting

Being used, the vehicle will often be broke along with it travels longer and longer. In order to recover vehicle to normal proper situation, also to pro-long its life, the trouble must be find out and then be disposed in an effective way.

* To shoot troubles of engine, see Engine Operating Instruction Manual which every vehicle have been e-quipped.

Checking and remedy of electrical system

fuel gauge not move

Spread fuel-gauge and take it iron, if the fuel-gauge needle point toward fuel-gauge have already break down or the instrument fuse was burn out, should check to fix or replace. If the

fuel-gauge still motionless, it means the fuel-gauge to break down.

The hydraulic indicator isn't bright: Dismantle hydraulic-pneumatic alert machine bottom, and take it iron. If the hydraulic-pneumatic indicator is bright at this time, the elucidation is hydraulic-pneumatic to report the machine switch damage, should re-place. If still not bright, explain the index sign lamp bulb burn bad, should replace, perhaps is launch the engine oil road contain break-down.

Dynamo is not work

Dynamo is work well, but indicator light is not work. The main cause of lamp connection is not well.

1. Electrical parts trouble shooting

Trouble symptom and probable cause	Checking and remedy
(1) Not start (a) Incorrect connection (b) Battery output Incorrect connection (c) Lubricant is not the standard. (d) Start the relay is incorrect.	(d) Clean the battery (b) Clean and tight it (c) replace lubricant (d) repair and replace
(2) Insufficient electric capacity (a) New battery without circulation of charge and discharge, or not been charged to rated quantity. (b) Generator without charge or enough charge. (c) Damaged pole plate. (d) Low level or improper specific gravity of electrolyte	(a) Charge as specified (b) Check connections and repair (c) Check and repair (d) Fill up electrolyte and charge battery with it separated from vehicle

Trouble symptom and probable cause	Checking and remedy
<p>(3) Too much waste of electrolyte</p> <p>(a) High charging amperage. Electrolyte vaporize or overflow</p> <p>(b) Leak battery</p>	<p>(a) Reduce the frequency of starting and shorten the starting time .Decrease amperage of charging current</p> <p>(b) Replace cover of the battery.</p>
<p>(4) Self-discharge of battery</p> <p>(a) Battery output cable short to ground</p> <p>(b) A short circuit between pole plates</p> <p>(c) Damaged or breakdown cell divider</p> <p>(d) Dirty external surface of battery case .Metal impurities mixed into electrolyte</p>	<p>(a) Clean the output cable ,dispose the short</p> <p>(b) Check and repair</p> <p>(c) Check and repair</p> <p>(d) Clean the battery case .Tighten shield .Replace electrolyte if necessary</p>

2. Clutch trouble shooting

Trouble symptom and probable cause	Checking and remedy
<p>(1) Shaking clutch</p> <p>a. Overloading too much vehicle</p> <p>b. Not start in low gear</p> <p>c. Defective release bearing or insufficient oil</p> <p>d. Corrugated fin cracked, friction lining worn, loose rivet, damper spring broken, or damper fin broken down.</p>	<p>a. Load by rated load</p> <p>b. Start in first gear when loading much</p> <p>c. Clean, lubricate or replace</p> <p>d. Replace</p>
<p>(2) Clutch Slip</p> <p>a. Thin friction lining, rivet reveal, or oil coat</p> <p>b. Weak pressure of diaphragm spring</p> <p>c. Too short free play of pedal</p> <p>d. Vehicle loads too much</p> <p>e. Not start in low gear</p> <p>f. The pedal is hold pressed when running</p>	<p>a. Clean, or rivet a new friction lining</p> <p>b. Replace</p> <p>c. Adjust to 3~5mm</p> <p>d. Load accord the rated load</p> <p>e. Start in low gear</p> <p>f. Change your bad driving habit</p>

Trouble symptom and probable cause	Checking and remedy
<p>(3) Clutch can't release completely</p> <ul style="list-style-type: none"> a. Too long free play of pedal b. Wear or crack locking collar c. Crack or distort of wave sheet d. Broken damper spring 	<ul style="list-style-type: none"> a. Adjust to 3~5mm b. Replace c. Replace d. Replace
<p>(4) Gears hard to mesh</p> <ul style="list-style-type: none"> a. High speed idle speed of engine b. Improper meshing of clutch c. Coherence of clutch plate d. Bend clutch slip sleeve 	<ul style="list-style-type: none"> a. Adjust the idle speed b. Adjust clutch c. Repair or replace d. Replace

3. Drive shaft trouble shooting

Trouble symptom and probable cause	Checking and remedy
<p>(1) Noise or vibration of driveshaft</p> <ul style="list-style-type: none"> a. Worn universal joint b. Bending of drive shaft c. Loose couple flange or center bracket bolts d. Defective center bracket rubber sleeve e. Insufficient lubrication 	<ul style="list-style-type: none"> a. Change spider direction or replace universal joint assembly b. Align or replace c. Retighten d. Replace e. Fill up after cleaning
<p>(2) Overheating center bracket</p> <ul style="list-style-type: none"> a. Too much tight of oil seal b. Too bigger a inclination between drive shaft and crankshaft c. Insufficient lubrication 	<ul style="list-style-type: none"> a. It will disappear along with travel longer b. Check and adjust the inclination c. Fill up regularly

4. Transmission trouble shooting

Trouble symptom and probable cause	Checking and remedy
(1) Gears break off	
a. Worn or damaged coupling	a. Replace the coupling
b. Loosen nuts or bolts	b. Tighten
c. Improperly adjusted linkage	c. Readjust
d. Distorted, worn, or crack spring or locking ball	d. Repair or replace parts
e. Worn shift fork and groove face	e. Replace shift fork
f. Worn synchronizer hub and sleeve	f. Replace
g. Worn or damaged synchronizer hub and engagement sleeve	g. Replace
h. Worn or damaged bearing of input shaft and output shaft	h. Replace bearing
i. Worn or damaged thrust ring and thrust washer	i. Replace
j. Loosen bolts which mount transmission to engine	j. Tighten

Trouble symptom and probable cause	Checking and remedy
(2) Gears hard to mesh	
a. High speed idle speed of engine	a. Adjust the idle speed
b. Improper meshing of clutch	b. Adjust clutch
c. Coherence of clutch plate	c. Repair or replace
d. Bend clutch slip sleeve	d. Replace
(3) Noise from transmission	
a. Loosen bolts which mount transmission to engine	a. Tighten
b. Worn gear or bearing	b. Replace
(4) Hard to shift	
a. Improper adjustment of shift knob	a. Adjust shift knob
b. Worn hinge joint or pin	b. Replace
c. Worn control mechanism	c. Replace
d. Loosen bolts or nuts	d. Check and tighten

5、Front axle trouble shooting

Trouble symptom and probable cause	Checking and remedy
(1) Hard steering, steering wheel doesn't return well a. Insufficient lubrication of steering linkage mechanism b. Improper alignment of front wheel c. Improper toe in of front wheel d. Improper camber and caster of king pin e. Worn thrust bearing f. Insufficient pressure of tire	a. Apply lubrication on king pin and ball stud b. Adjust c. Adjust d. Check the linear for wear, and check knuckle and tie rod for deviation, replace if necessary e. Replace f. Inflate properly
(2) Abnormal worn tire a. Improper position fix of front wheel b. Improper pressure of front tire	a. Adjust, and replace if necessary b. Adjust, and inflate

Trouble symptom and probable cause	Checking and remedy
(3) Vibrate oscillate a. Improper position fix of front wheel b. Worn king pin linear c. Improper pretightening of hub bearing d. Worn hub bearing e. Loosen ball stud of tie rod f. Loosen nuts on U-type bolt g. Loosen hub nuts h. Distorted wheel i. Unbalance wheel j. Wheel deviation k. Asymmetry or insufficient inflation of tire (a) front wheel location is wrong (b) damage of the main bush (c) the tight of wheel hub is wrong (d) damage of wheel hub axle	a. Adjust, and replace if necessary b. Replace linear c. Adjust d. Replace e. Replace all end parts of tie rod f. Tighten g. Tighten h. Replace i. Adjust and balance j. Adjust k. Adjust, inflate (b) replace (c) adjust (d) replace

Trouble symptom and probable cause	Checking and remedy
(e)cross pull rod ball end is loosen (f)U type of nut and blot are loosen (g)the nut of wheel hub are loosen (h)the distortion of wheel (i)the wheel are not imbalance (j)the wap of wheel (k)shortage of the air pressure	(e)change the parts (f)tighten (g)tighten (h)replace (i)adjust the balance (j)adjust (k)adjust ,charge air
(4)leak grease from wheel hub (a)damage of oil seal (b)hub cover is loosen (c)too much grease	(a)replace (b)tighten (c)use grease to fix

6. Rear axle trouble shooting

Trouble symptom and probable cause	Checking and remedy
(1) Abnormal noise from rear axle a. Worn or damaged pinion bearing b. Worn or damaged side bearing of differential c. Loosen pinion bearing d. Loosen differential bearing e. Worn pinion and ring gear f. Worn thrust washer g. Worn differential spider h. Worn pinion and ring gear i. Worn or damaged side gear and planetary gear j. Loosen tightening bolts of ring gear k. Improper contact between ring gear and pinion l. Worn pinion spline m. Worn rear half shaft spline n. Loosen hub bearing o. Worn hub bearing	a. Replace bearing b. Replace bearing c. Adjust preload d. Adjust preload e. Adjust tooth space f. Replace g. Replace h. Replace i. Replace j. Tighten k. Replace or adjust l. Replace m. Replace n. Replace o. Adjust bearing preload

Trouble symptom and probable cause	Checking and remedy
<p>p. Loose tightening bolts of differential case q. Insufficient oil r. Bad oil</p>	<p>p. Tighten q. Fill up r. Replace</p>
<p>(2) half shaft seal Leaking a. Jammed rear axle vent hole b. Bad lubrication c. Tight between pinion and driven gear, tight bearing, and tight over on bearing</p>	<p>a. Fill up and readjust b. Replace lubrication accord the season c. Readjust</p>
<p>(3) Hot rear axle a. Oil leak because of damaged seal gasket, loosen oil drain plug, and jammed vent hole, result in insufficient lubrication b. Bad lubrication c. Tight over between pinion and driven gear, tight over on bearing</p>	<p>a. Fill up and readjust b. Replace lubrication accord the season c. Readjust</p>

7. Steering mechanism trouble shooting

Trouble symptom and probable cause	Checking and remedy
<p>(1) Hard to steer and steering wheel with bad return a. Distorted main shaft, sliding shaft or column b. Loosen universal joint or column cover c. Improper rotation of steering wheel bearing d. Insufficient lubrication of steering linkage mechanism e. Low pressure tire</p>	<p>a. Replace parts b. Replace universal joint c. Replace parts d. Fill up lubrication e. Inflate properly</p>
<p>(2) Shake of steering wheel, instable steering a. Loosen steering linkage mechanism b. Unbalance front wheel c. Pendulate too much d. Damaged grinding wheel e. Heavy wear or too big clearance of steering linkage mechanism</p>	<p>a. Tighten properly b. Balance the wheel c. Adjust d. Replace e. Replace parts</p>

Trouble symptom and probable cause	Checking and remedy
(3) Wander front wheel a. One of front brake or damper is disabled b. One of front tire low pressure c. Disalign or break of front leaf spring d. Damaged grinding wheel e. Improper toe in of front wheel	a. Adjust the brake clearance or replace damper b. Inflate tires c. Check front spring assembly d. Adjust or replace e. Readjust
(4) Power steering bump leaking a. Damaged oil seal or O ring b. Damaged oil seal locking nuts or oil-drain plug	a. Replace b. Repair
(5) Heavy steering a. Bad steering gear b. Bad steering gear c. Improper preload sector gear bearing	a. Replace piston set b. Check pump for output pressure, replace if necessary c. Adjust the pretightening force of bearing

8. Running brake trouble shooting

Trouble symptom and probable cause	Checking and remedy
(1) shortage of brake (a) adjust the brake room (b) have some dirty things (c) brake cam and shoe brake are rustiness (d) brake room epithelia and pipe are leak air (e) brake valve lead air (f) the distance between brake and shoe plate is too large (g) brake drum (h) have dirty things on the pipe (i) enter air to brake valve is slowly	(a) adjust the pull rod (b) use buck to washing (c) clean the rustiness and grease (d) change epithelia ,check the air part (e) change valve base (f) adjust (g) adjust and change (h) clean it (i) check enter air of the karat
(2) brake moment is partial (a) brake shoe plate unseemliness (b) one side of brake shoe plate is rustiness (c) shoe plate have oil dirt (d) the wheel is empty. (e) brake drum is change	(a) adjust (b) grease (c) clean (d) ordain air press (e) adjust and grind

9. Parking brake failure shooting

Trouble symptom and probable cause	Checking and remedy
<ul style="list-style-type: none"> a. Big clearance between brake pad and drum b. Oil coat on brake pad or drum c. Badly worn friction pad 	<ul style="list-style-type: none"> a. Adjust the clearance until both its upper and lower is 0.65mm b. Clean with water c. Replace

10. Suspension trouble shooting

Trouble symptom and probable cause	Checking and remedy
(1) Broken leaf spring <ul style="list-style-type: none"> a. Load too much or partial to one wheel b. Frequent emergency brake, drive too fast on uneven road c. Loosen U-bolt. Loosen or broken spring clamp d. Failed damper 	<ul style="list-style-type: none"> a. Load properly as rated b. Keep your mind on driving, so that avoid emergency brake and slower speed on uneven road c. Tighten U-bolt. Tighten or replace spring clamp. d. Repair or replace
2) Noise in driving	Check and replace rubber suspension part
(3) Bad absorption <ul style="list-style-type: none"> a. Insufficient damping fluid b. Having no maintaince regularly c. Damaged rubber collar 	<ul style="list-style-type: none"> a. Fill up as rated b. Maintain regularly c. Replace

11. Wheel trouble shooting

Trouble symptom and probable cause	Checking and remedy
(1) Badly worn tire a. High or low tire pressure b. Too much overloading or dissymmetrical loading c. Loosen wheel hub bearing d. Improper toe-in of front wheel e. Frequent emergency brake, flare up when starting, or accelerate suddenly f. No wheel transposition	a. Inflate by specification b. Load as rated c. Adjust d. Adjust the toe-in until it is 3~6mm (for diagonal tire) and 1~3mm (for radial tire) e. Drive stably, don't drive too fast f. Transposition regularly

VII. Automotive model table of trucks

No.	Vehicle type	Engine type	Engine power (ml/kW)	Outside dimension (l×w×h) (mm)	Inside dimension of the cargo body (l×w×h) (mm)	Axle Base (mm)
1	HFC1048K type truck	YZ4102QF YZ4105QF	3856/70.6 4087/75	5910×2096×2250	4130×1960×400	3308
2	HFC1048KR1 type truck	CY4102BQ	3856/70.6	5910×2096×2250	3800×1960×400	3308
3	HFC1048K1 type truck	CY4102BZLQ YZ4102ZLQ	3856/88 3432/81	5910×2096×2250	4130×1960×400	3308
4	HFC1048K1R1 type truck	CY4102BZLQ YZ4102ZLQ	3856/88 3432/81	5910×2090×2250	3800×1960×400	3308
5	HFC1048KD type truck	CY4102BZLQ CY4102BZQ	3856/88 3856/88	5910×2096×2250	4130×1960×400	3308

HFC1048

series trucks

No.	Vehicle type	Engine type	Engine power (ml/kW)	Outside dimension (l×w×h) (mm)	Inside dimension of the cargo body (l×w×h) (mm)	Axle Base (mm)
6	HFC1048KR1D type truck	CY4102BZLQ CY4102BZQ	3856/88 3856/88	5910×2090×2250	3800×1960×400	3308
7	HFC1048K8 type truck	CY4102BZLQ YZ4102ZLQ	3856/88 3432/81	5910×2096×2250	4130×1960×400	3308
8	HFC1048K8R1 type truck	CY4102BZLQ YZ4102ZLQ	3856/88 3432/81	5910×2090×2250	3800×1960×400	3308
9	HFC1048K9 type truck	HFC4DA1-1	2771/68	5910×2096×2250	4130×1960×400	3308
10	HFC1048K9R1 type truck	HFC4DA1-1	2771/68	5910×2096×2250	3800×1960×400	3308

No.	Umber of leaf springs (front/rear)	tyre	Tread (front/rear) (mm)	Cross vehicle weight (kg)	Max load capacity (kg)	Curb wigh (kg)		Front/rear suspension (mm)
1	12/14	7.00-16	1665/1525 1665/1485	4480	1920	2560	23/14	1105/1497
2	12/14	7.00-16	1665/1525 1665/1485	4480	1920	2560	23/14	1105/1497
3	12/14	7.00-16	1665/1525 1665/1485	4480	1725	2560	23/14	1105/1497
4	12/14	7.00-16	1665/1525 1665/1485	4480	1725	2560	23/14	1105/1497
5	12/14	7.00-16 7.50-16	1665/1525 1665/1485	4480	1725	2560	23/14	1105/1497

No.	Umber of leaf springs (front/rear)	tyre	Tread (front/rear) (mm)	Cross vehicle weight (kg)	Max load capacity (kg)	Curb wigh (kg)		Front/rear suspension (mm)
6	12/14	7.00-16 7.50-16	1665/1525 1665/1485	4480	1725	2560	23/14	1105/1497
7	12/14	7.00-16	1665/1525 1665/1485	4480	1725	2560	23/14	1105/1497
8	12/14	7.00-16	1665/1525 1665/1485	4480	1725	2560	23/14	1105/1497
9	12/14	7.00-16	1665/1525 1665/1485	4365	1790	2380		1185/2050
10	12/14	7.00-16	1665/1525 1665/1485	4365	1785	2380		1185/2050

VIII、Appendix

Main lubricating position and the lubricant name(for reference)

Description of the oil in lubricating table (for reference)

Main files along with the vehicle

Table one Main lubricating position and the lubricant name(for reference)

No.	Lubricating position	Symbol of the lubricant	Number of the ubricating	maintenace cycle				
				everyday	First time	Seconde time	Third time	Every season
1	universal joint of the driveshaft	G	3					
2	spline of the driveshaft	G	1	fill			replace	
3	battery terminal	G	2	fill			replace	replace
4	transmission	Z	6L(reference)	fill		replace	replace	
5	oil cup of the clutch brake master cylinder	Y	suitable	one change one year				
6	steering gear	Z	1		fill		replace	
7	steering knuckle pin and ball pin of the drag link and the tie rod	G	各 2	check	fill			
8	Filer cartride		1			replace	replace	

No.	Lubricating position	Symbol of the lubricant	Number of the ubricating	maintenace cycle				
				everyday	First time	Seconde time	Third time	Every season
9	generator	G	2	fill				
10	Power steering	D	1		fill	replace	replace	
11	bearing of the front ,rear hub	ZL	Each 2				replace	
12	Shack absorber	Q	2				fill	
13	Water pump bearing	G	1		fill	fill		
14	Transimission drive gear front bearing	G	1			replace		
15	Rear axle	Z	1		fill		replace	
16	Engine lubrication system		1	fill		replace		replace
17	Cooling system drive mechanism	ZL	2		fill			

Table two Description of the oil in lubricating table (for reference)

Symbol in the table	Lubricant
B	L-BCD4 oil GB11123(summer) ,LECD30 oil GB11123(winter)
J	15W/20 or 15W/40 thickened oil
G	GB49 2# lime base grease
ZL	GB5671 universal lithium base grease
Q	Half HU-20 gasoline engine oil(GB2537)and half 45# transformer oil (GB2536)
Y	brake fluid JG3(GB10830)
Z	medium-load vehicle gear oil(GL-4) 85W/90
D	L-HM46(GB11119), the below zero is L-LM32(GB11119) antiwear hydraulic oil.

Table three Tightening torque of main fastening pieces (for reference)

Number	Name	Tightening torque(N·m)
1	Nuts of steering tie rod ball pin	186±20(19±2)
2	Nuts connected the transmission and the clutch housing	68.8-93.2(7-9.5)
3	Intermediate driveshaft flange nuts	343-539(35-55)
4	tyer nut	196-245(20-25)
5	Diving gear flange nuts	220-250(23-25.5)
6	Fixing nuts of the steering straight arm	441±49(45±5)
7	U-bolt of the front leaf spring	250
8	U-bolt of the rear leaf spring	350
9	steering fix bolt	68.8-88.2(7-9)
10	Fixing nuts of steering flexural arm	441±49(45±5)
11	Steering-wheel fix nut	49-78.4(5-8)
12	Transmission flange nuts	>166.7(17)
13	Pitman arm shaft nut	196-235.2(20-24)

Main files along with the vehicle

- 1.《Operating specification of HFC1040 series trucks》
- 2.《Operating specification of engine》
3. Products certification

The nameplate of JAC series trucks is located on the right side of longitudinal member beside front suspension.

ANHUI JIANGHUAI AUTOMOBILE CO., LTD.
Address: 176# Dongliu Road Hefei City
Telephone: 0551-2296374
Postalcode: 230022
Network address: <http://www.jac.com.cn>